

NO.	PART NAME	PART#	REQ'D	MATERIAL
1	PIPE FLANGE 4 3/4"X1 1/2" NPT	B44452	1	304 SS
2	HEX JAM NUT 7/16"-20	N716S	1	18-8 SS
3	HEX LOCK NUT 5/16"-18	R20ANS	1	18-8 SS
4	TAMPER RESISTANT SCREW 10-32 X 3/8"	TRS1032SS	2	302 SS
5	VACUUM RELIEF VALVE GASKET 1 1/2"	VV1529G	1	BLACK EPDM PC
6	VACUUM RELIEF VALVE BUSHING 1 1/2"	VV15S41SB	1	303 SS
7	SPRING 3/4" X 3 5/16"	VV15S41SP	1	18-8 SS
8	VACUUM RELIEF VALVE STEM 1 1/2"	VVN15S4SA	1	304/18-8 SS
9	VACUUM RELIEF VALVE BODY ASSEMBLY 1 1/2"	VVN15S4VBA	1	304 SS
10	VACUUM RELIEF VALVE CAP	VVNS4TC	1	304 SS

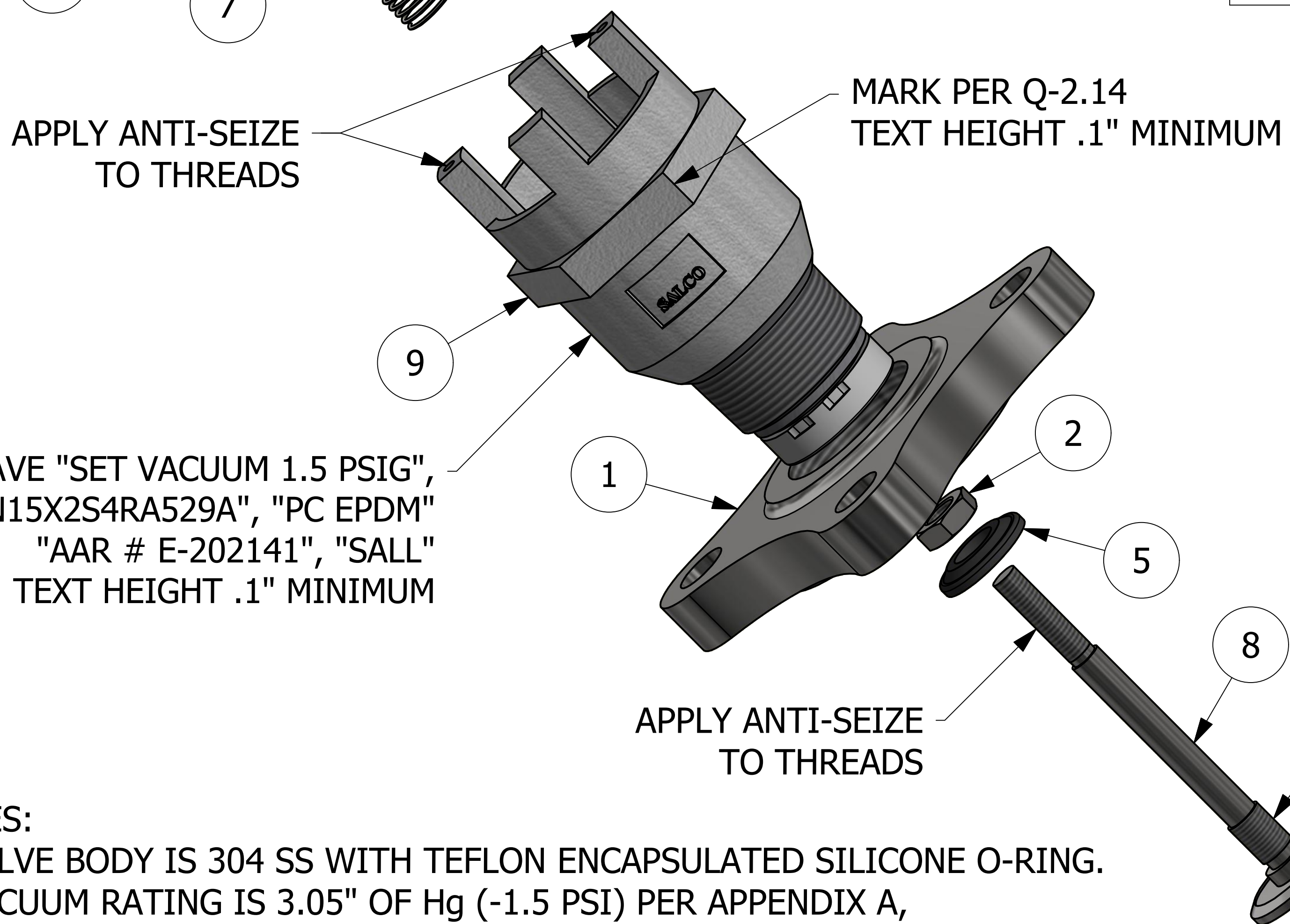

ENGRAVE "SET VACUUM 1.5 PSIG",  
"VVN15X2S4RA529A", "PC EPDM"  
"AAR # E-202141", "SALL"  
TEXT HEIGHT .1" MINIMUM

- NOTES:
1. VALVE BODY IS 304 SS WITH TEFLON ENCAPSULATED SILICONE O-RING.
  2. VACUUM RATING IS 3.05" OF Hg (-1.5 PSI) PER APPENDIX A, SECTION 4.10 OF AAR TANK CAR MANUAL.
  3. AAR APPROVAL # E-202141.
  4. TEST PER Q-2.15.7
  5. SEE DOCUMENT Q-2.14 FOR MARKING PROCEDURE.
  6. SEE DOCUMENT WPS-M10 FOR WELDING PROCEDURE.
  7. WELD ACCEPTANCE CRITERIA TO MEET DOCUMENT D-005.

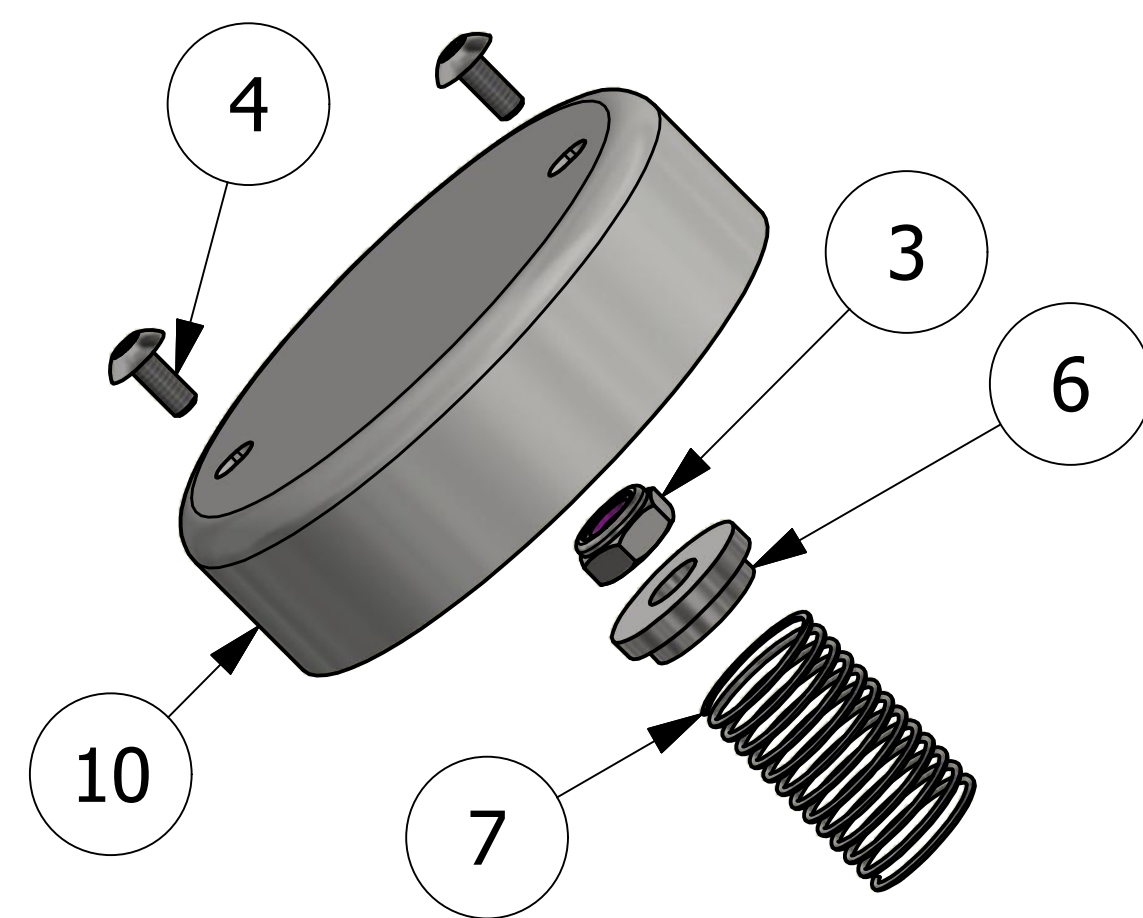
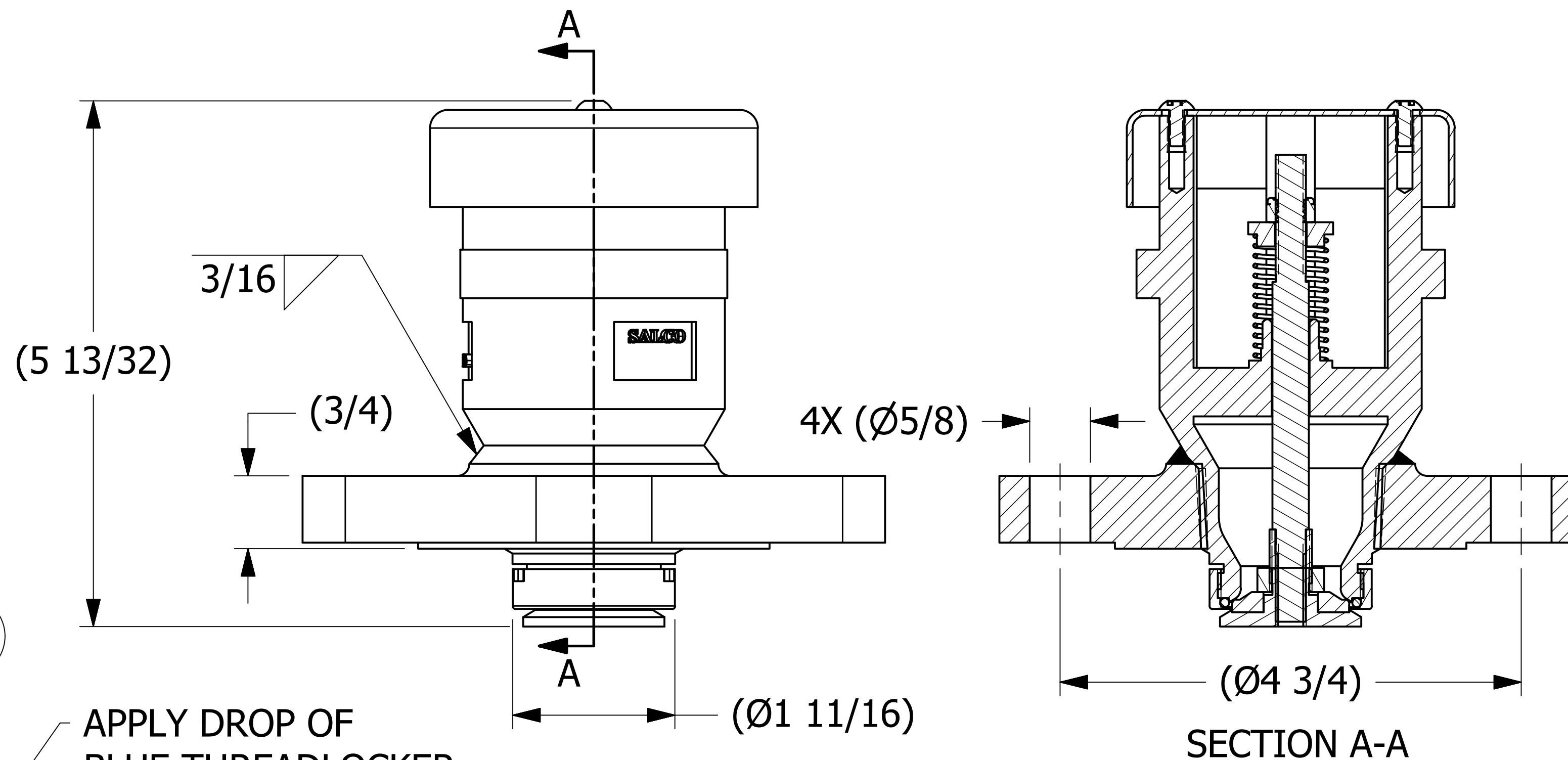

APPLY DROP OF  
BLUE THREADLOCKER

C	WEB	3/7/22	UPDATED MARKING; REMOVED LABEL
B	WEB	9/4/20	AAR # WAS E-099034; UPDATED TITLE BLOCK
A	JG	7/24/18	RELEASED FOR PRODUCTION
REV	BY	DATE	DESCRIPTION

UNLESS OTHERWISE SPECIFIED DIMENSIONAL TOLERANCES	DRAWN BY:	JG
FRACTIONAL: ±1/16	CHECKED BY:	VD
X.XX: ±.03	PROTOTYPE DATE:	7/5/2018
X.XXX: ±.015	APPROVED FOR PRODUCTION BY:	MJW
ANGULAR: ±1°	PRODUCTION DATE:	7/24/2018
DEBURR ALL SHARP EDGES. ALL MACHINED SURFACES TO HAVE A 125 RMS FINISH. UNLESS NOTED OTHERWISE.	SIZE:	D
THIRD ANGLE PROJECTION	DRAWING #:	47413

**SALCO PRODUCTS, INC.**

PART NAME: **VACUUM RELIEF VALVE 1 1/2"X2" FLANGED**

MATERIAL: **SEE BOM**

PROJECT #: **R180703** SHEET #: **1 OF 1** SCALE: **1 : 1**

PART #: **VVN15X2S4RA529A**