

NO.	PART NAME	PART#	REQ'D	MATERIAL
1	HEX JAM NUT 7/16"-20	N716S	1	18-8 SS
2	HEX LOCK NUT 5/16"-18	R20ANS	1	18-8 SS
3	TAMPER RESISTANT SCREW 10-32 X 3/8"	TRS1032SS	2	302 SS
4	VACUUM RELIEF VALVE GASKET 1 1/2"	VV1512G	1	BLACK VITON GF-600S
5	VACUUM RELIEF VALVE BUSHING 1 1/2"	VV15S41SB	1	303 SS
6	SPRING 3/4" X 3 5/16"	VV15S41SP	1	18-8 SS
7	VACUUM RELIEF VALVE STEM 1 1/2"	VVN15S4SA	1	304/18-8 SS
8	VACUUM RELIEF VALVE BODY 1 1/2"	VVN15S6RAVB	1	316 SS
9	VACUUM RELIEF VALVE CAP	VVNS4TC	1	304 SS

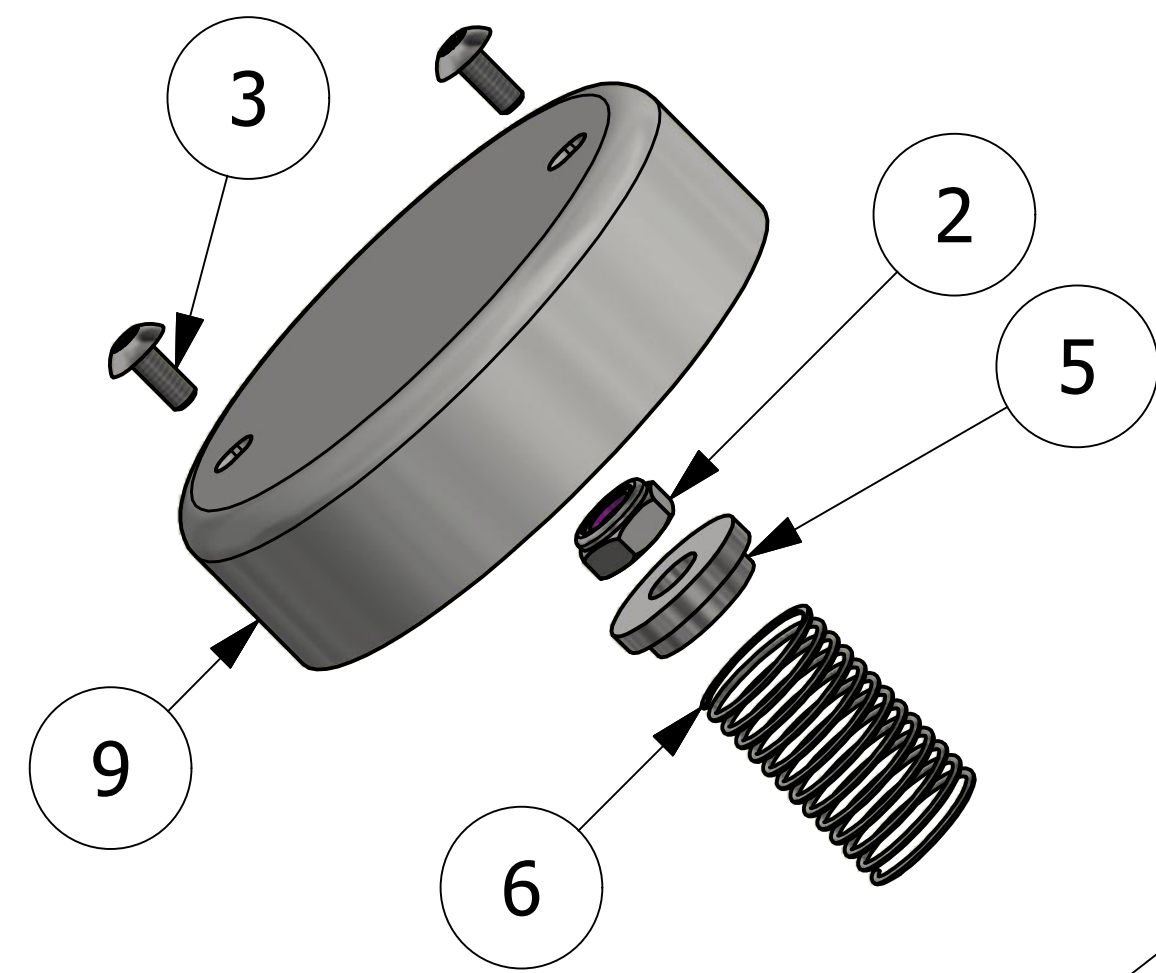

APPLY ANTI-SEIZE TO THREADS

MARK PER Q-2.14 TEXT HEIGHT .1" MINIMUM

ENGRAVE "SET VACUUM 3/4 PSIG", "VVN15S6RA112A", "VITON GF" "AAR # E-202141", "SALL" TEXT HEIGHT .1" MINIMUM

APPLY ANTI-SEIZE TO THREADS

APPLY DROP OF BLUE THREADLOCKER

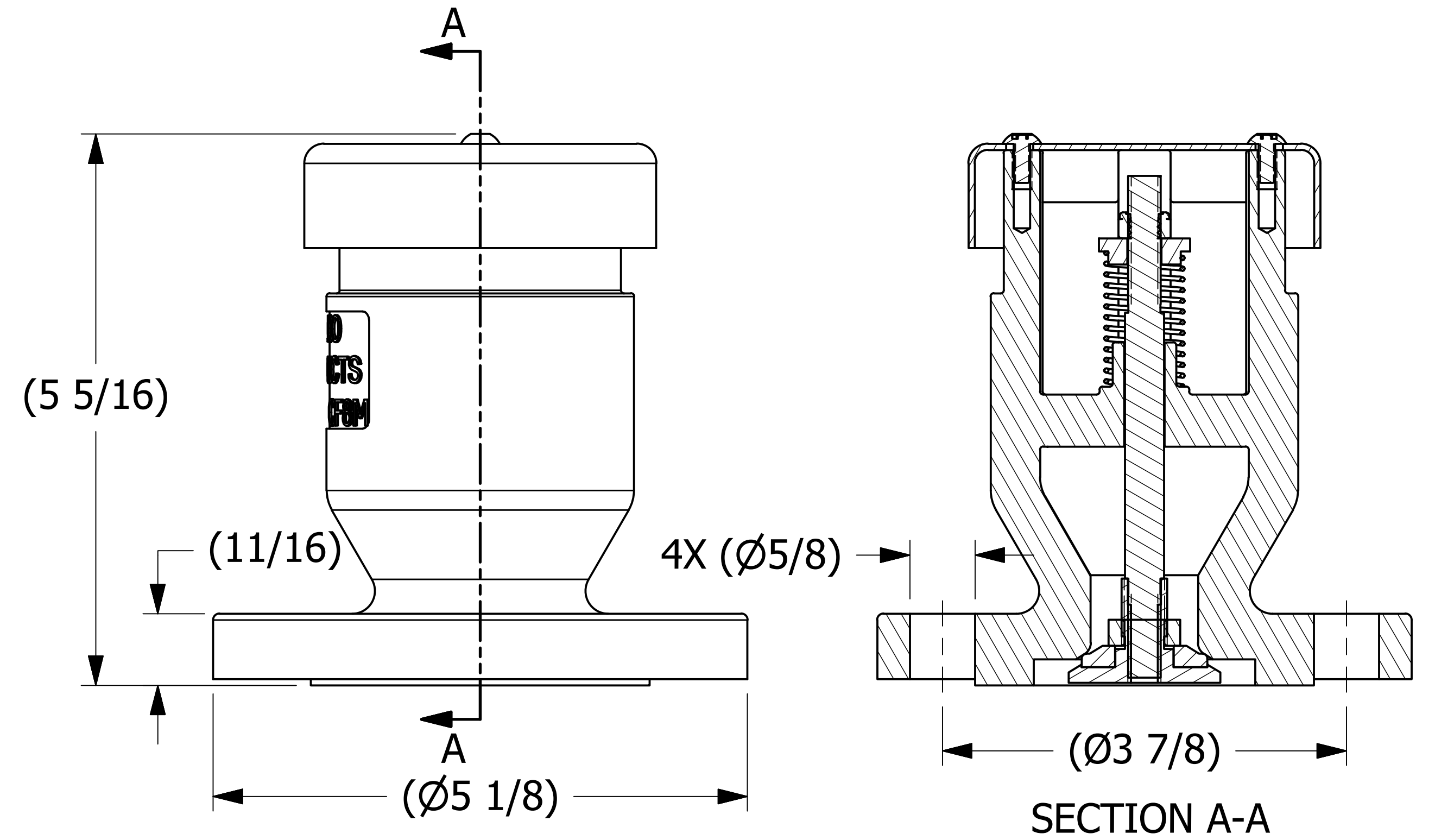

NOTES:

1. VALVE BODY IS 316 SS, CF8M.
2. VACUUM RATING IS 1.53" OF Hg (-.75 PSI) PER APPENDIX A, SECTION 4.10 OF AAR TANK CAR MANUAL.
3. AAR APPROVAL # E-202141.
4. TEST PER Q-2.15.7.
5. SEE DOCUMENT Q-2.14 FOR MARKING PROCEDURE.

E	WEB	7/23/21	UPDATED MARKINGS; REMOVED LABEL
D	WEB	9/4/20	AAR # WAS E-099034; UPDATED TITLE BLOCK
C	JG	3/20/18	Q-2.14 WAS QAP5A-1; Q-2.15.7 WAS QAP4C-1
B	WEB	2/17/14	"VVN15" TO "VVN15S6RA112A", BHCS73742 TO TRS1032SS
A	RJP	1/14/14	RELEASED FOR PRODUCTION
REV	BY	DATE	DESCRIPTION

UNLESS OTHERWISE SPECIFIED DIMENSIONAL TOLERANCES	DRAWN BY:	RJP
FRACTIONAL: ±1/16	CHECKED BY:	WRB
X.XX: ±.03	PROTOTYPE DATE:	1/14/2014
X.XXX: ±.015	APPROVED FOR PRODUCTION BY:	CHL
ANGULAR: ±1°	PRODUCTION DATE:	1/14/2014
DEBURR ALL SHARP EDGES. ALL MACHINED SURFACES TO HAVE A 125 RMS FINISH. UNLESS NOTED OTHERWISE. THIRD ANGLE PROJECTION	SIZE:	D
	DRAWING #:	38056

SALCO PRODUCTS, INC.

PART NAME: **VACUUM RELIEF VALVE 1 1/2" FLANGED**

MATERIAL: **SEE BOM**

PROJECT #: **140113FR** SHEET #: **1 OF 1** SCALE: **1:1**

PART #: **VVN15S6RA112A**