

NO.	PART NAME	PART#	REQ'D	MATERIAL
1	DUST CAP 2"	K20IBCDC7A	1	DI/BRASS
2	QUICK CONNECT ADAPTER 2" THREAD ON	K2IMPA	1	DI
3	S-HOOK 1/4"	SC25SH	1	CS Z/P

NOTES:

1. HARDWARE IS CARBON STEEL.
2. CASTINGS ARE DUCTILE OR MALLEABLE IRON.
3. CROSSOVER ARMS ARE BRASS.
4. GASKET IS BLACK VITON B.

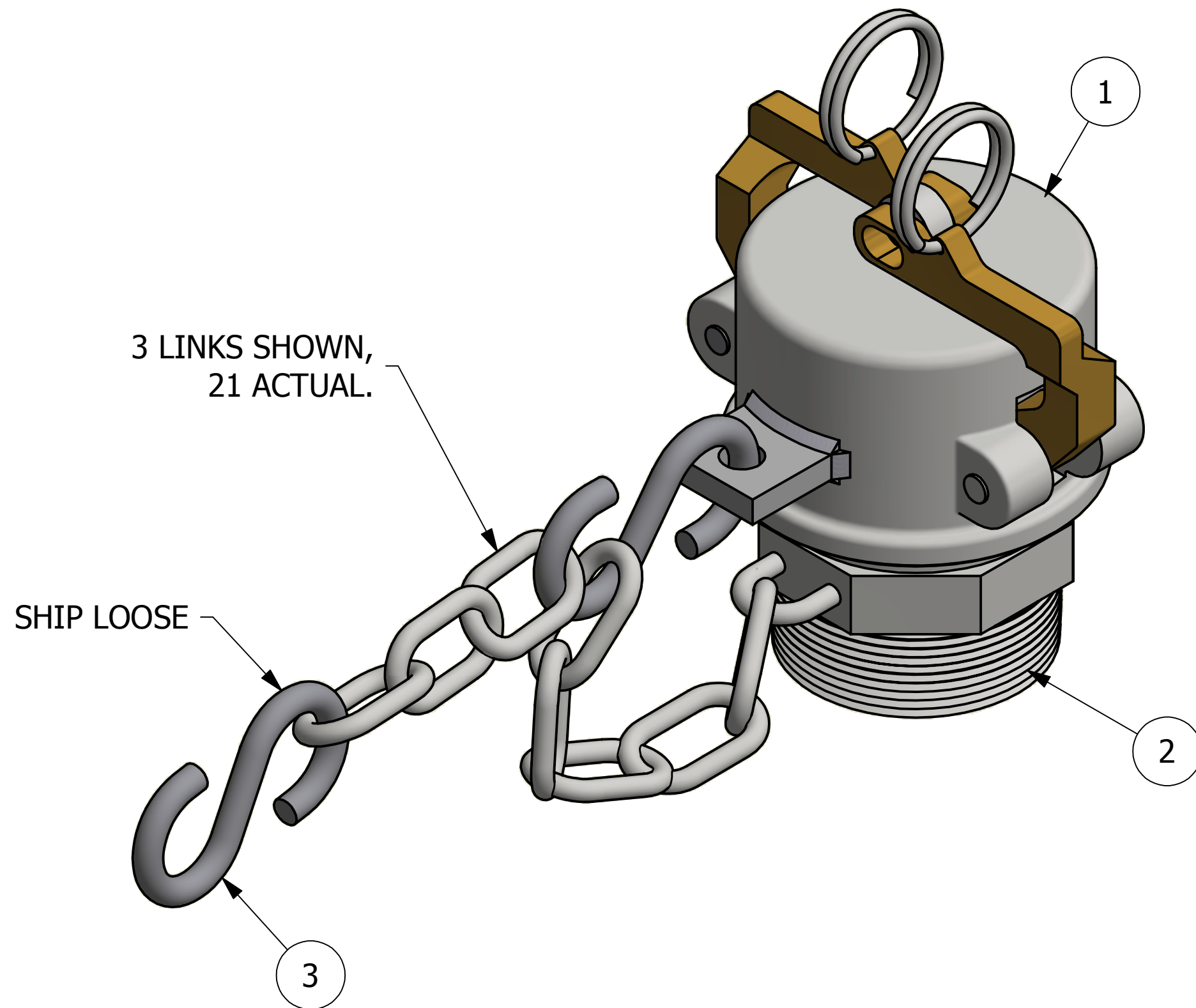
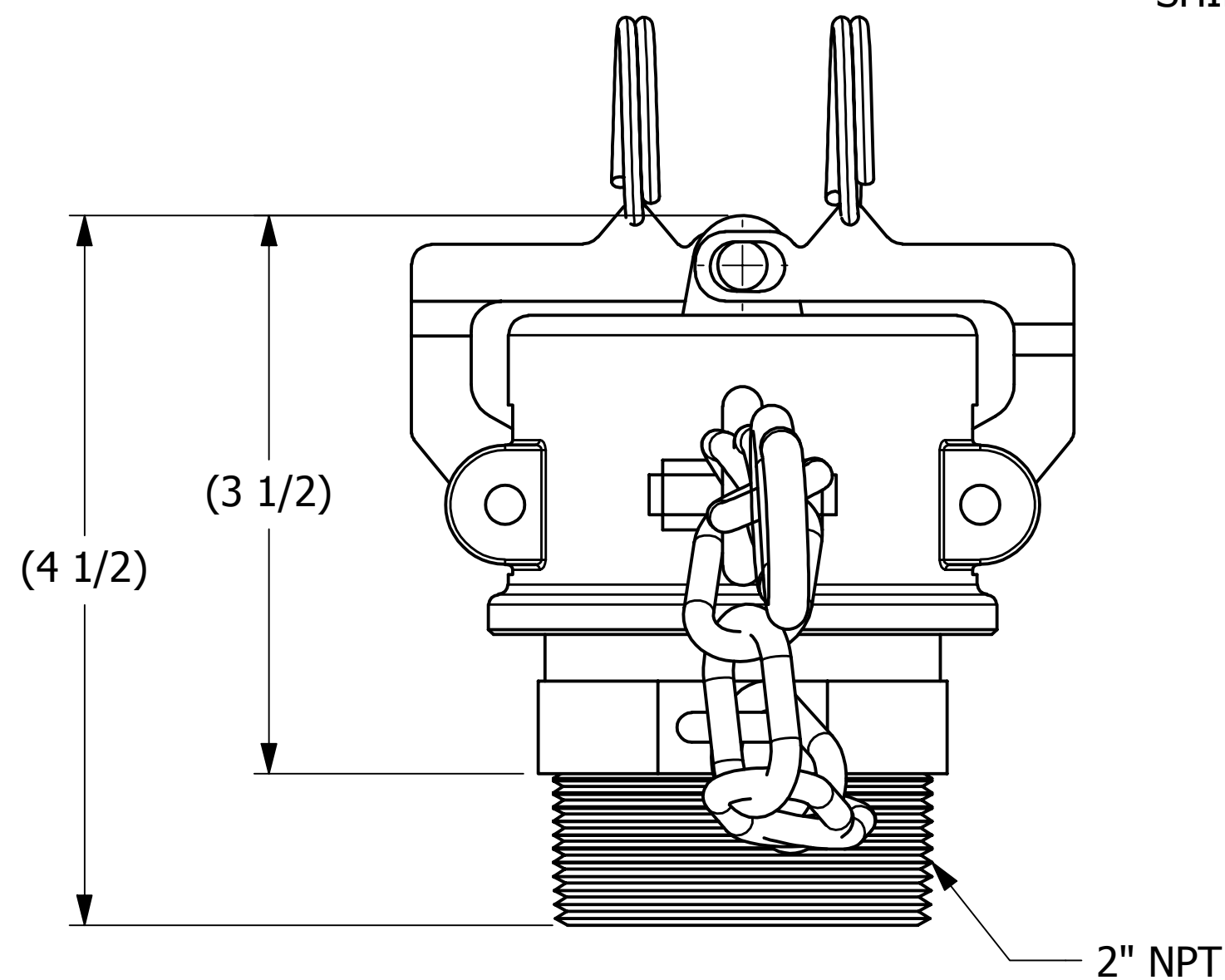

A	WEB	6-3-14	RELEASED FOR PRODUCTION
REV	BY	DATE	DESCRIPTION

UNLESS OTHERWISE SPECIFIED DIMENSIONAL TOLERANCES FRACTIONAL: $\pm 1/16$ X.XX: $\pm .03$ X.XXX: $\pm .015$ ANGLE: $\pm 1^\circ$ DEBURR ALL SHARP EDGES. ALL MACHINED SURFACES TO HAVE A 125 RMS FINISH UNLESS NOTED OTHERWISE. THIRD ANGLE PROJECTION	DRAWN BY:	WEB
	CHECKED BY:	CHL
	PROTOTYPE BY:	WEB
	PROTOTYPE DATE:	6/2/2014
	APPROVED FOR PRODUCTION BY:	WEB
	PRODUCTION DATE:	6/3/2014

SALCO PRODUCTS, INC.		
PART NAME: TOP FITTING ASSEMBLY 2" THREAD ON		
MATERIAL: SEE BOM/NOTE		
PROJECT #:	SHEET #:	SCALE:
R140602FR	1 OF 1	1:1
DRAWING #:	PART #:	
C39160	K20IBCUMP7A	