

NO.	PART NAME	PART#	REQ'D	MATERIAL
1	BOTTOM OUTLET CAP 4"	PBC40A	1	NYLON
2	ADAPTER GASKET 5 1/4" RR	SSA4G53	1	WHITE GYLON 3545
3	REPAIR LINK 1/4"	SCA1L	1	CS Z/P

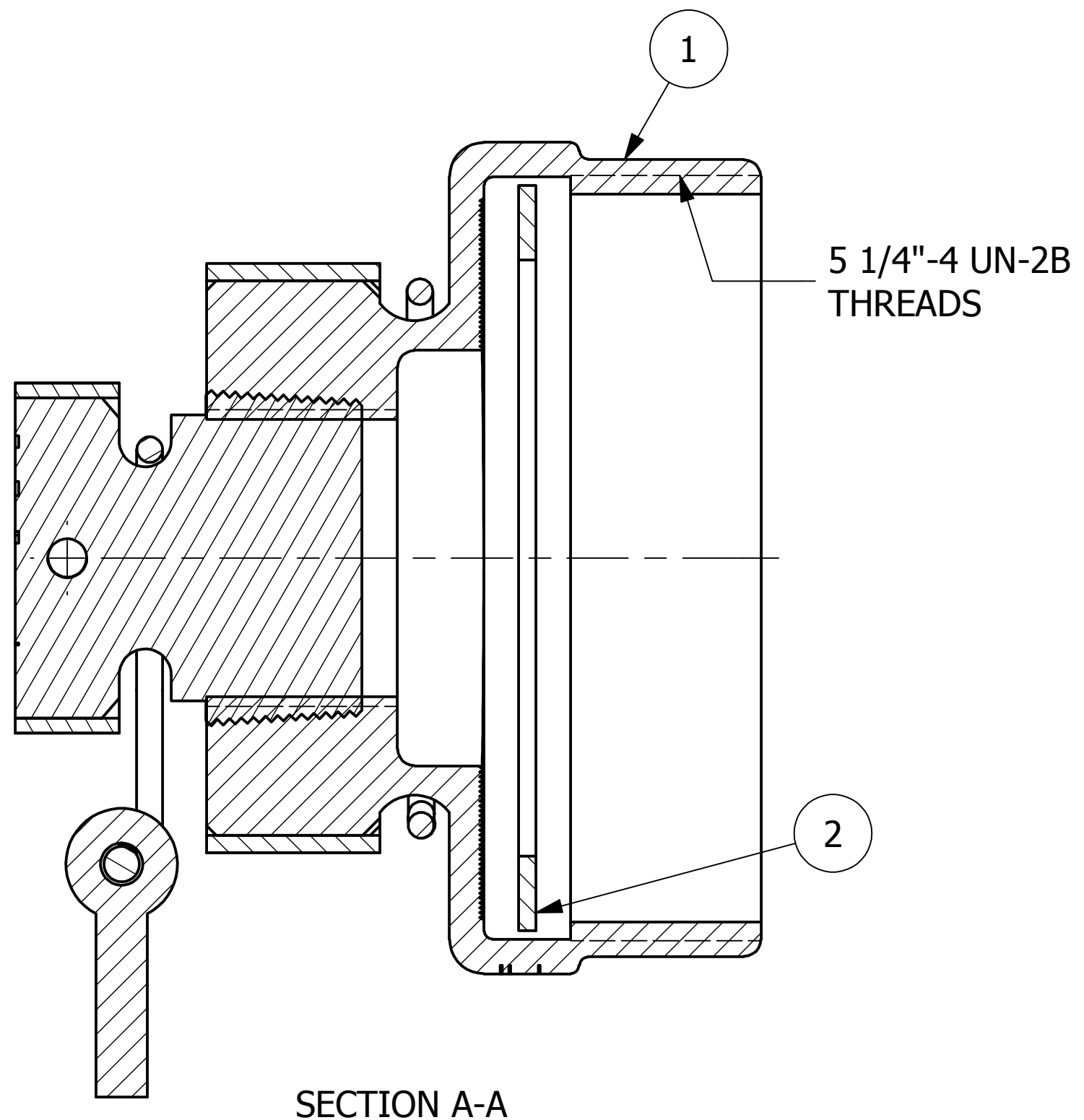
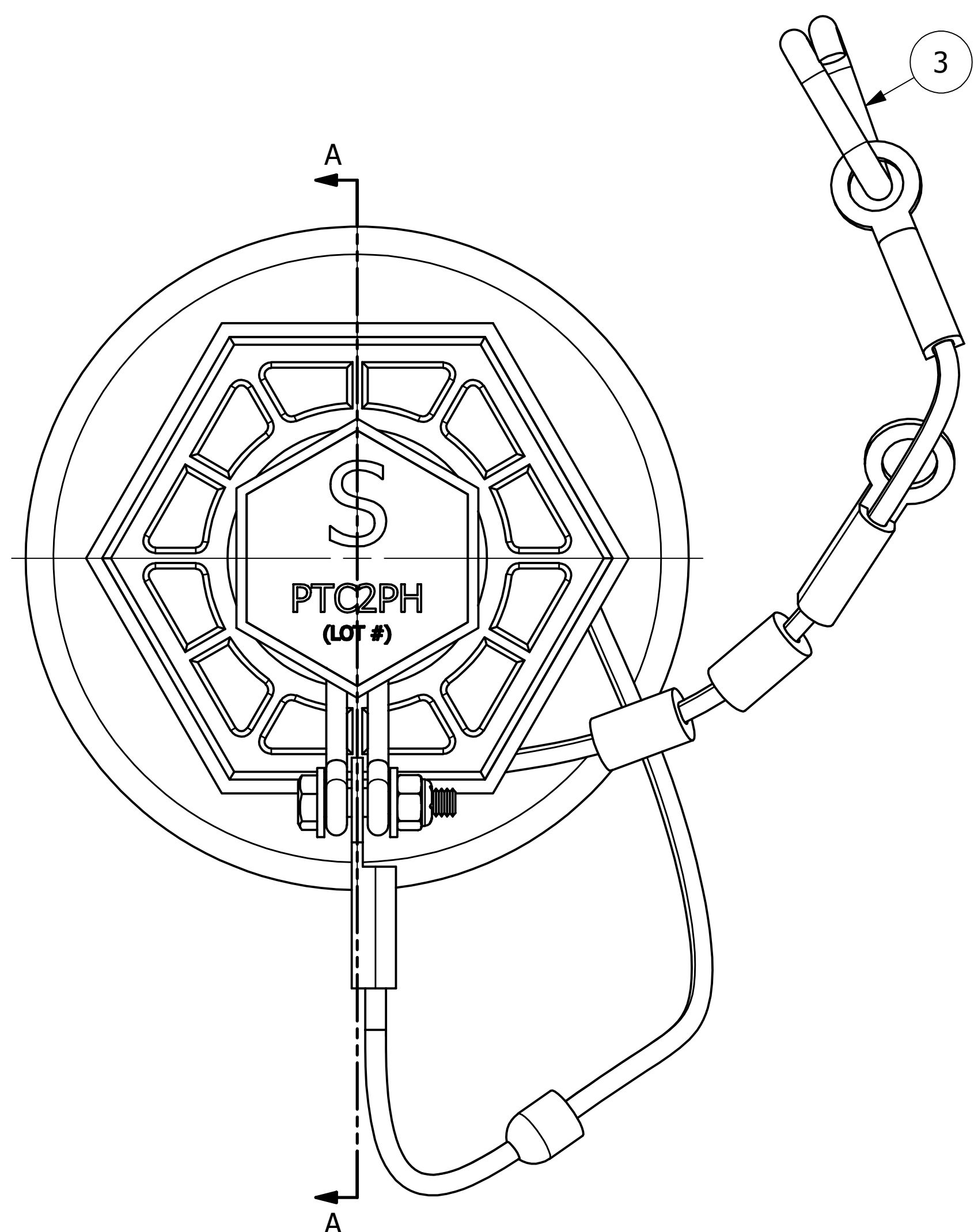

- NOTES:
1. AAR APPROVAL# E-099015.
  2. 5 1/4"-4 UN-2B THREADS CONFORM TO ANSI B1.1 AND FIGURE E18 OF AAR TANK CAR MANUAL.

REV	BY	DATE	DESCRIPTION
A	RJP	6-7-16	RELEASED FOR PRODUCTION

<small>UNLESS OTHERWISE SPECIFIED DIMENSIONAL TOLERANCES FRACTIONAL: ±1/16 X.XX: ±.03 X.XXX: ±.015 ANGLE: ±1° DEBURR ALL SHARP EDGES. ALL MACHINED SURFACES TO HAVE A 125 RMS FINISH UNLESS NOTED OTHERWISE.</small>	DRAWN BY:	WEB
	CHECKED BY:	VD
	PROTOTYPE BY:	WEB
	PROTOTYPE DATE:	6/3/2016
	APPROVED FOR PRODUCTION BY:	VD
	PRODUCTION DATE:	6/7/2016

**SALCO PRODUCTS, INC.**

PART NAME:  
**BOTTOM OUTLET CAP 4"**

MATERIAL: **SEE BOM**

PROJECT #: **R160524** SHEET #: **1 OF 1** SCALE: **1:1**

DRAWING #: **C43807** PART #: **PBC4053A**