

| NO. | PART NAME | PART # | REQ'D | MATERIAL |
|-----|----------------------|--------|-------|----------|
| 1 | BOTTOM OUTLET CAP 4" | PBC400 | 1 | NYLON |
| 2 | PLUG 2" | PTC2PH | 1 | NYLON |

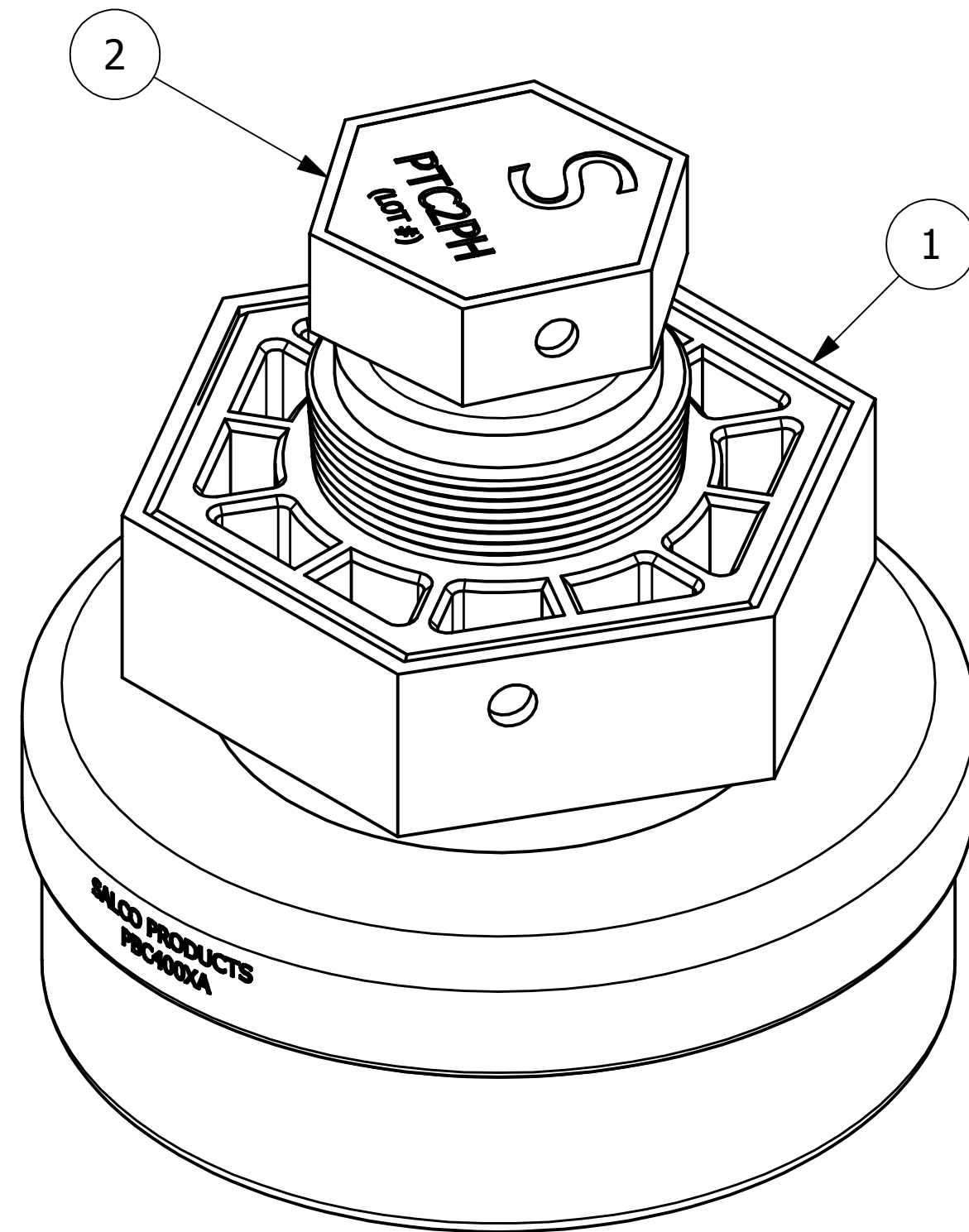

NOTES:

1. 5 1/4"-4 UN-2B THREADS CONFORM TO ANSI B1.1 AND FIGURE E18 FROM THE AAR TANK CAR MANUAL.
2. OTHER GASKET MATERIALS AVAILABLE BY REQUEST.
3. AAR APPROVAL # E099015.

| REV | BY | DATE | DESCRIPTION |
|-----|-----|---------|-----------------------------|
| A | RJP | 6-28-17 | AAR APPROVAL # WAS E-989047 |

SALCO PRODUCTS, INC.

PART NAME:
BOTTOM OUTLET CAP 4"

MATERIAL: **SEE BOM**

PROJECT #: **WAG0070** SHEET #: **1 OF 1** SCALE: **1:1**

DRAWING #: **C18394** PART #: **PBC400WP**

| | | |
|---|-----------------------------|-----------|
| UNLESS OTHERWISE SPECIFIED DIMENSIONAL TOLERANCES FRACTIONAL: $\pm 1/16$ X.XX: $\pm .03$ X.XXX: $\pm .015$ ANGLE: $\pm 1^\circ$ DEBURR ALL SHARP EDGES. ALL MACHINED SURFACES TO HAVE A 125 RMS FINISH UNLESS NOTED OTHERWISE. THIRD ANGLE PROJECTION | DRAWN BY: | CHL |
| | CHECKED BY: | ACC |
| | PROTOTYPE BY: | CHL |
| | PROTOTYPE DATE: | 9/10/2003 |
| | APPROVED FOR PRODUCTION BY: | ACC |
| PRODUCTION DATE: | 9/10/2003 | |