

15 LINKS ACTUAL
16TH IS CUT

NO.	PART NAME	PART #	REQ'D	MATERIAL
1	QUICK CONNECT ADAPTER 3" THREAD ON	TE3SA	1	316 SS
2	HEX BOLT 3/8"-16X2"	RP103MS	1	18-8 SS
3	HEX LOCK NUT 3/8"-16	RP103MN	1	18-8 SS
4	FLAT WASHER 3/8"	RP103MW	2	18-8 SS
5	CHAIN LINK 3/8"	SC80	16	18-8 SS
6	S-HOOK 3/8"X3 1/2"	SC38SHS	1	18-8 SS
7	ADAPTER GASKET 5 1/4" RR	SSA4G	1	BLACK NITRILE
8	SOCKET CAP SCREW 3/8"-16X1/2"	T4SHCS	2	18-8 SS

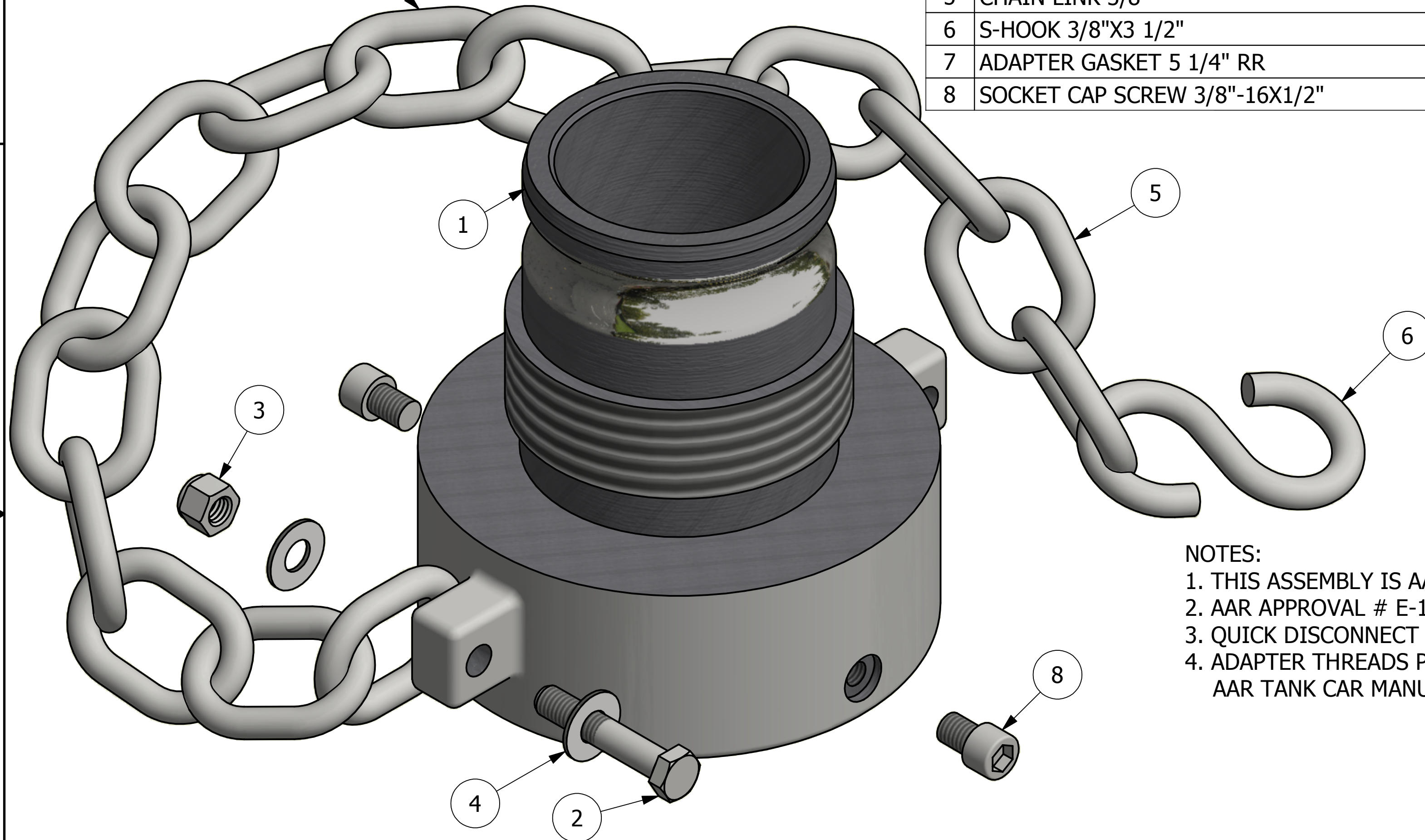

NOTES:

1. THIS ASSEMBLY IS AAR AND DOT APPROVED.
2. AAR APPROVAL # E-149523.
3. QUICK DISCONNECT MEETS A-A-59326D.
4. ADAPTER THREADS PER FIGURE E.18 IN THE AAR TANK CAR MANUAL.

REV	BY	DATE	DESCRIPTION
C	WEB	6-5-15	E-149523 WAS E-049013, UPDATED NOTES
B	RJP	12-20-13	UPDATED TO INVENTOR, ADDED NOTES RP103MW WAS TSW916
A	CHL	6-19-03	NEW PART ADDED TO SYSTEM

UNLESS OTHERWISE SPECIFIED DIMENSIONAL TOLERANCES FRACTIONAL: $\pm 1/16$ X.XX: $\pm .03$ X.XXX: $\pm .015$ ANGLE: $\pm 1^\circ$ DEBURR ALL SHARP EDGES. ALL MACHINED SURFACES TO HAVE A 125 RMS FINISH UNLESS NOTED OTHERWISE.	DRAWN BY:	CHL
	CHECKED BY:	ACC
	PROTOTYPE BY:	CHL
	PROTOTYPE DATE:	12/16/2013
	APPROVED FOR PRODUCTION BY:	ACC
	PRODUCTION DATE:	6/18/2003

SALCO PRODUCTS, INC.		
PART NAME: QUICK CONNECT ADAPTER 3" THREAD ON		
MATERIAL: SEE BOM		
PROJECT #: WAG0030	SHEET #: 1 OF 1	SCALE: 1:1
DRAWING #: C18119	PART #: TE3SA1A	