

3/8" TALL  
LETTERS, RAISED

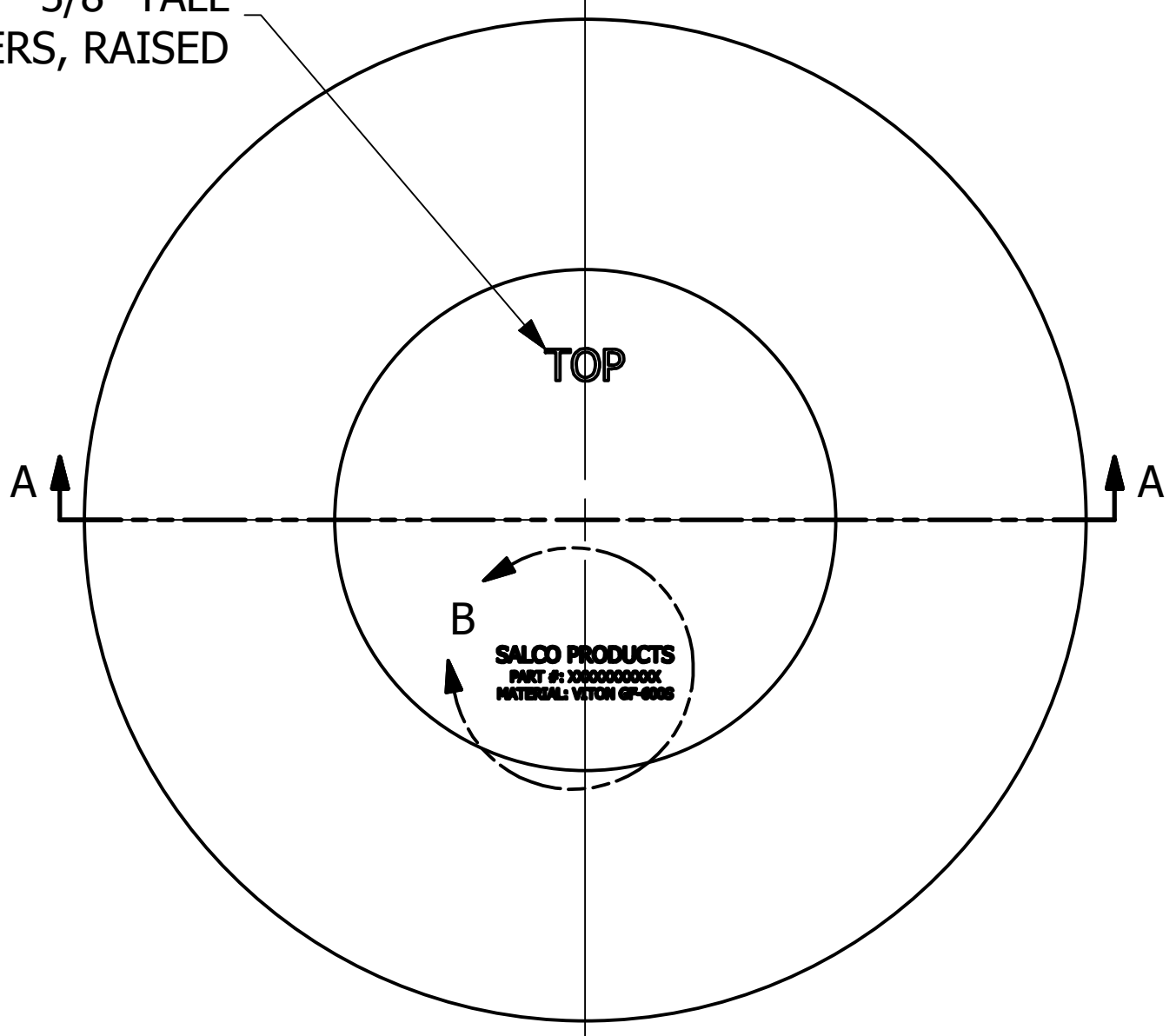

TOP VIEW

3/8" TALL  
LETTERS, RAISED

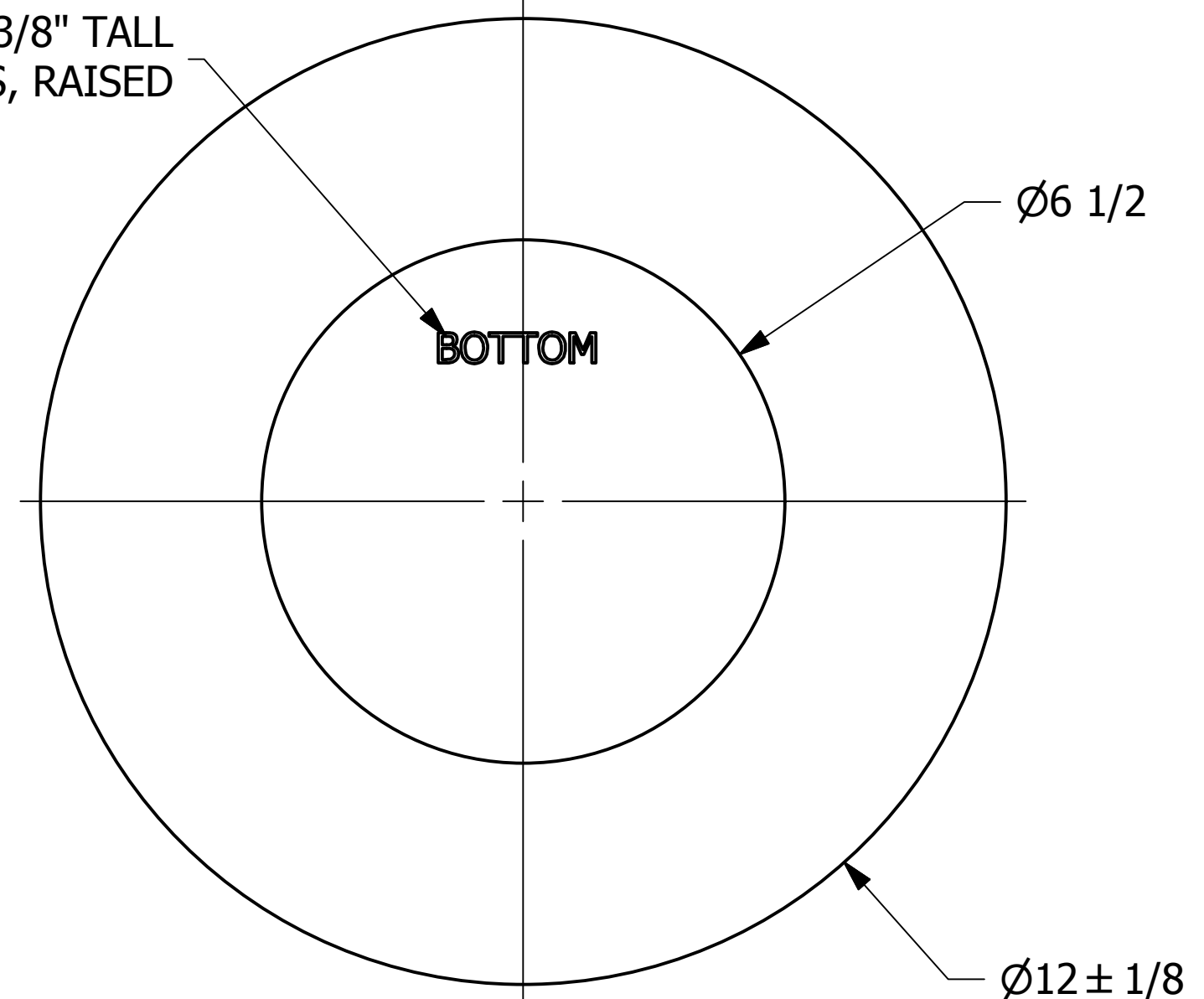

BOTTOM VIEW

3/16" TALL  
LETTERS, RAISED



DETAIL B

1/8" TALL  
LETTERS, RAISED

.25 TYP.

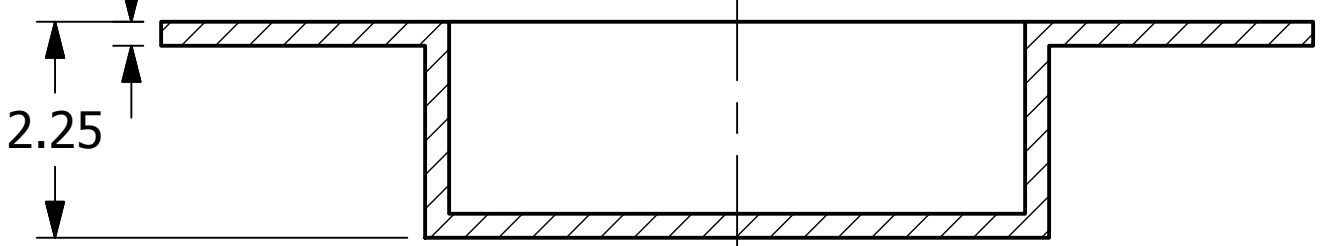

SECTION A-A

NOTES:

1. MATERIAL IS BLACK VITON® GF-600S DUPONT U2A S26/G26 75 DURO ± 5.
2. MUST MEET Q-2.14.1.

| REV | BY  | DATE     | DESCRIPTION                      |
|-----|-----|----------|----------------------------------|
| E   | CHL | 7-16-18  | ADDED Q-2.14.1 NOTE              |
| D   | GS  | 8-16-12  | UPDATED NOTES AND MATERIAL SPEC. |
| C   | AJB | 3-24-11  | UPDATED TOLERANCE ON OD.         |
| B   | AJB | 2-8-11   | UPDATED TOLERANCES. WAS ±.03.    |
| A   | VD  | 01-05-11 | ADDED PART TO SYSTEM.            |

|  |                             |            |
|--|-----------------------------|------------|
| <small>UNLESS OTHERWISE SPECIFIED<br/>DIMENSIONAL TOLERANCES<br/>FRACTIONAL: ±1/16<br/>X.XX: ±.03<br/>X.XXX: ±.015<br/>ANGLE: ±1°<br/>DEBURR ALL SHARP EDGES.<br/>ALL MACHINED SURFACES TO<br/>HAVE A 125 RMS FINISH UNLESS<br/>NOTED OTHERWISE.</small> | DRAWN BY:                   | REH        |
|  | CHECKED BY:                 | VD         |
|  | PROTOTYPE BY:               | REH        |
|  | PROTOTYPE DATE:             | 10/26/2010 |
|  | APPROVED FOR PRODUCTION BY: | VD         |
|  | PRODUCTION DATE:            | 8/21/2012  |

**SALCO PRODUCTS, INC.**

PART NAME: **FILL HOLE COVER GASKET 8"**

MATERIAL: **SEE NOTE**

PROJECT #: **WAG0894** SHEET #: **1 OF 1** SCALE: **1:2**

DRAWING #: **C29718** PART #: **TC8VFHG12**