

NO.	PART NAME	PART #	REQ'D	MATERIAL
1	HEX BOLT 3/8-16 X 1 3/4"	EA111B	1	CS Z/P
2	HEX LOCK NUT 3/8"-16	EA111N	1	CS Z/P
3	QUICK CONNECT ADAPTER 4" THREAD ON	K4IA	1	DUCTILE IRON
4	FLAT WASHER 3/8" USS	KL103FW	2	CS Z/P
7	ADAPTER GASKET 5 1/4" RR	SSA4G3	1	BLACK EPDM SC
25	CHAIN LINKS 3/8"X15	SC4315C	1	AISI 1008 CS
26	S-HOOK 3/8"X3 1/2"	SC38SHS	1	18-8 SS

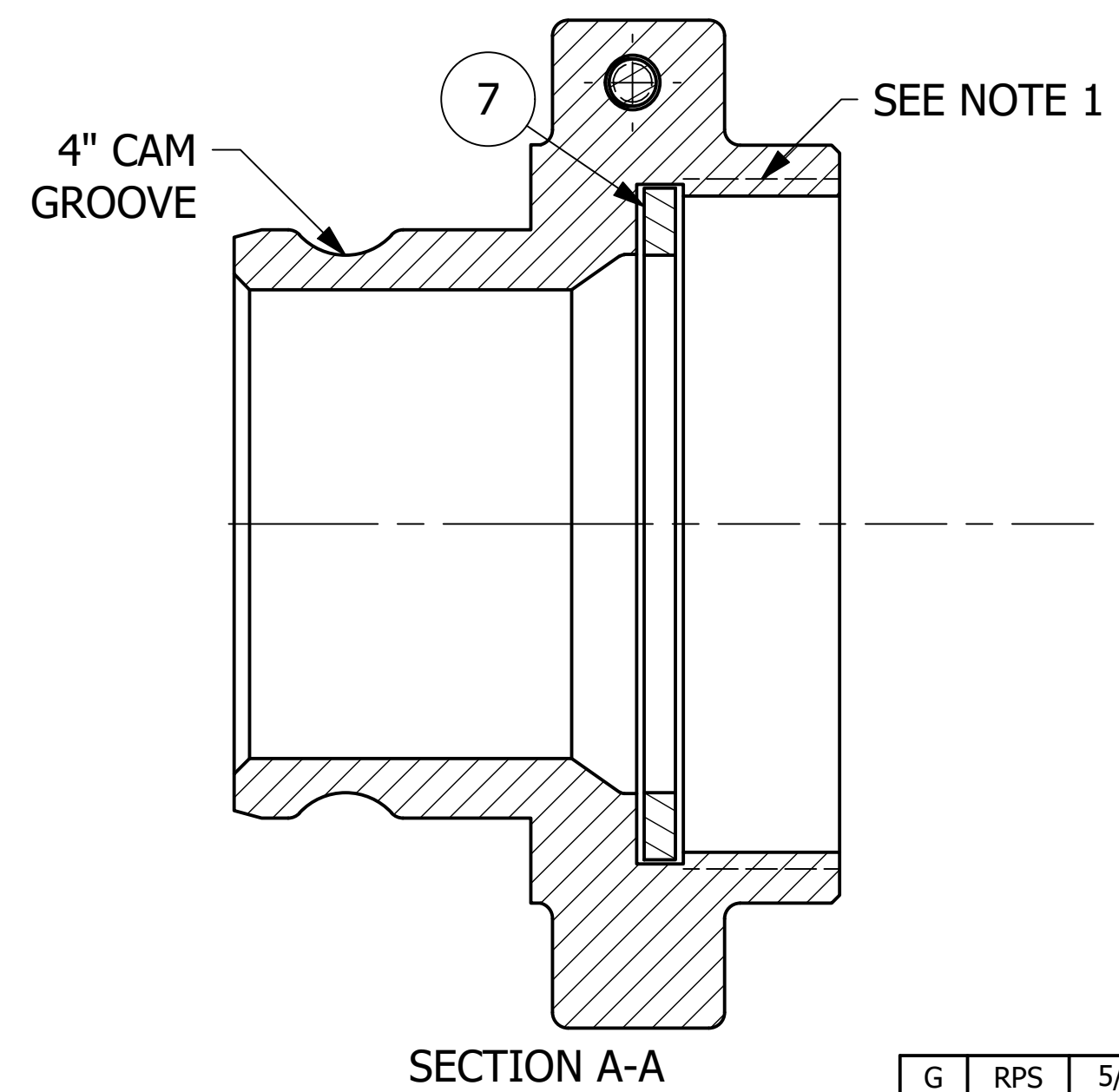

SECTION A-A

- NOTES:
1. 5-1/4" - 4 UN 2B THREADS CONFORM TO ANSI B1.1 STANDARD AND FIGURE E18 FROM AAR TANK CAR MANUAL.
 2. THIS ASSEMBLY IS NOT DOT APPROVED AND CAN BE USED ONLY ON AAR STENCILED CARS.
 3. QUICK DISCONNECT MEETS A-A-59326D.
 4. ADAPTER IS DUCTILE IRON (FERRITIZED/ANNEALED) AND MEETS ASTM A395 GRADE 60-40-18 REQUIREMENTS.
 5. SPRAY WITH USDA APPROVED WHITE MINERAL OIL OR VEGETABLE OIL AS A RUST INHIBITOR.
 6. AAR APPROVAL # E-232133.

G	RPS	5/6/24	AAR APPROVAL # WAS E-139514.
F	WEB	5/5/22	REPLACED 16X SC43 W/ SC4315C; UPDATED TITLE BLOCK
E	RJP	10/29/13	AAR APPROVAL # WAS E-039015 MIL SPEC WAS MIL-C-27487G
D	GS	7/24/12	DRAWING ADDED TO NETWORK.
C	TAJ	6/24/11	AAR APPROVAL # WAS E-039015
B	CHL	12/30/03	AAR APPROVAL # WAS E-939034
A	CHL	6/5/03	NEW PART ADDED TO SYSTEM
REV	BY	DATE	DESCRIPTION

UNLESS OTHERWISE SPECIFIED DIMENSIONAL TOLERANCES FRACTIONAL: ±1/16 X.XX: ±.03 X.XXX: ±.015 ANGLE: ±1° DEBURR ALL SHARP EDGES. ALL MACHINED SURFACES TO HAVE A 125 RMS FINISH UNLESS NOTED OTHERWISE. THIRD ANGLE PROJECTION	DRAWN BY:	CHL
	CHECKED BY:	ACC
	PROTOTYPE DATE:	5/9/2001
	APPROVED FOR PRODUCTION BY:	ACC
	PRODUCTION DATE:	5/9/2001
	SIZE:	C
DRAWING #:	15729	



PART NAME: QUICK CONNECT ADAPTER 4" THREAD ON

MATERIAL: SEE BOM
 PROJECT #: 010508 SHEET #: 1 OF 1 SCALE: 3:4
 PART #: K4IA3A