

15X Ø3/8" CS CHAIN LINKS
APPROXIMATE LENGTH 21"

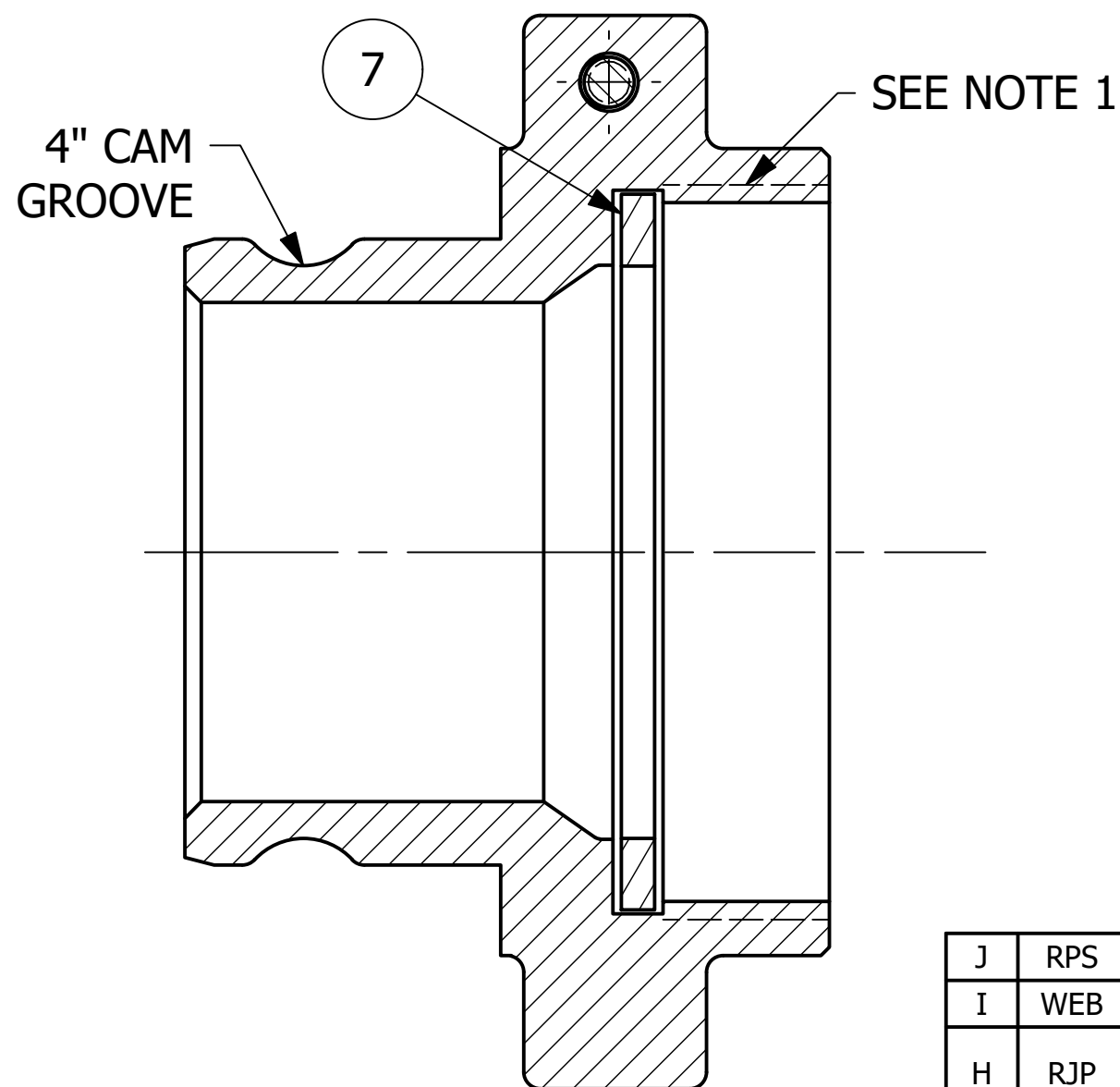

SECTION A-A

NO.	PART NAME	PART#	REQ'D	MATERIAL
1	HEX BOLT 3/8-16 X 1 3/4"	EA111B	1	CS Z/P
2	HEX LOCK NUT 3/8"-16	EA111N	1	CS Z/P
3	QUICK CONNECT ADAPTER 4" THREAD ON	K4IA	1	DUCTILE IRON
4	FLAT WASHER 3/8" USS	KL103FW	2	CS Z/P
5	S-HOOK 3/8"X3 1/2"	SC38SH	1	CS Z/P
6	CHAIN LINKS 3/8"X15	SC4315C	1	AISI 1008 CS
7	ADAPTER GASKET 5 1/4" RR	SSA4G	1	BLACK NITRILE

- NOTES:
- 5 1/4"-4 UN 2B THREADS CONFORM TO ANSI B1.1 STANDARD AND FIGURE E18 FROM AAR TANK CAR MANUAL.
 - THIS ASSEMBLY IS NOT DOT APPROVED AND CAN BE USED ONLY ON AAR STENCILED CARS.
 - QUICK DISCONNECT MEETS A-A-59326D.
 - ADAPTER IS DUCTILE IRON (FERRITIZED/ANNEALED) AND MEETS ASTM A395 GRADE 60-40-18 REQUIREMENTS.
 - SPRAY WITH USDA APPROVED WHITE MINERAL OIL OR VEGETABLE OIL AS A RUST INHIBITOR.
 - AAR APPROVAL # E-232133.

J	RPS	5/6/24	AAR APPROVAL # WAS E-139514.
I	WEB	5/5/22	REPLACED 16X SC43 W/ SC4315C
H	RJP	10/29/13	AAR APPROVAL # WAS E-039015 MIL SPEC WAS MIL-C-27487G
G	GS	7/24/12	DRAWING ADDED TO NETWORK.
F	TAJ	6/24/11	AAR APPROVAL # WAS E-039015
E	ACC	8/29/03	AAR APPROVAL # WAS E939034
D	FOD	3/6/00	CHANGED PART #, WAS K4IAA
C	ACC	1/15/99	CHAIN MATERIAL WAS CS Z/P
B	MRC	9/4/97	S-HOOK WAS 5/16" & CHAIN WAS 1/4" DIAMETER
A	ACC	11/30/95	UPDATED B.O.M.
REV	BY	DATE	DESCRIPTION

UNLESS OTHERWISE SPECIFIED DIMENSIONAL TOLERANCES FRACTIONAL: ±1/16 X.XX: ±.03 X.XXX: ±.015 ANGLE: ±1° DEBURR ALL SHARP EDGES. ALL MACHINED SURFACES TO HAVE A 125 RMS FINISH UNLESS NOTED OTHERWISE THIRD ANGLE PROJECTION	DRAWN BY: ACC
	CHECKED BY:
	PROTOTYPE DATE: 9/17/1993
	APPROVED FOR PRODUCTION BY: ACC
	PRODUCTION DATE: 9/17/1993
	SIZE: C
	DRAWING #: 5513

SALCO PRODUCTS, INC.

PART NAME: **QUICK CONNECT ADAPTER 4" THREAD ON**

MATERIAL: **SEE BOM**

PROJECT #: SHEET #: **1 OF 1** SCALE: **3:4**

PART #: **K4IA1A**