

NO.	PART NAME	PART#	REQ'D	MATERIAL
1	QUICK CONNECT ADAPTER 4" THREAD ON	TE4IA2A	1	DUCTILE IRON
2	QUICK CONNECT CAP 4" THREADED	TE4IDC2A	1	DUCTILE IRON

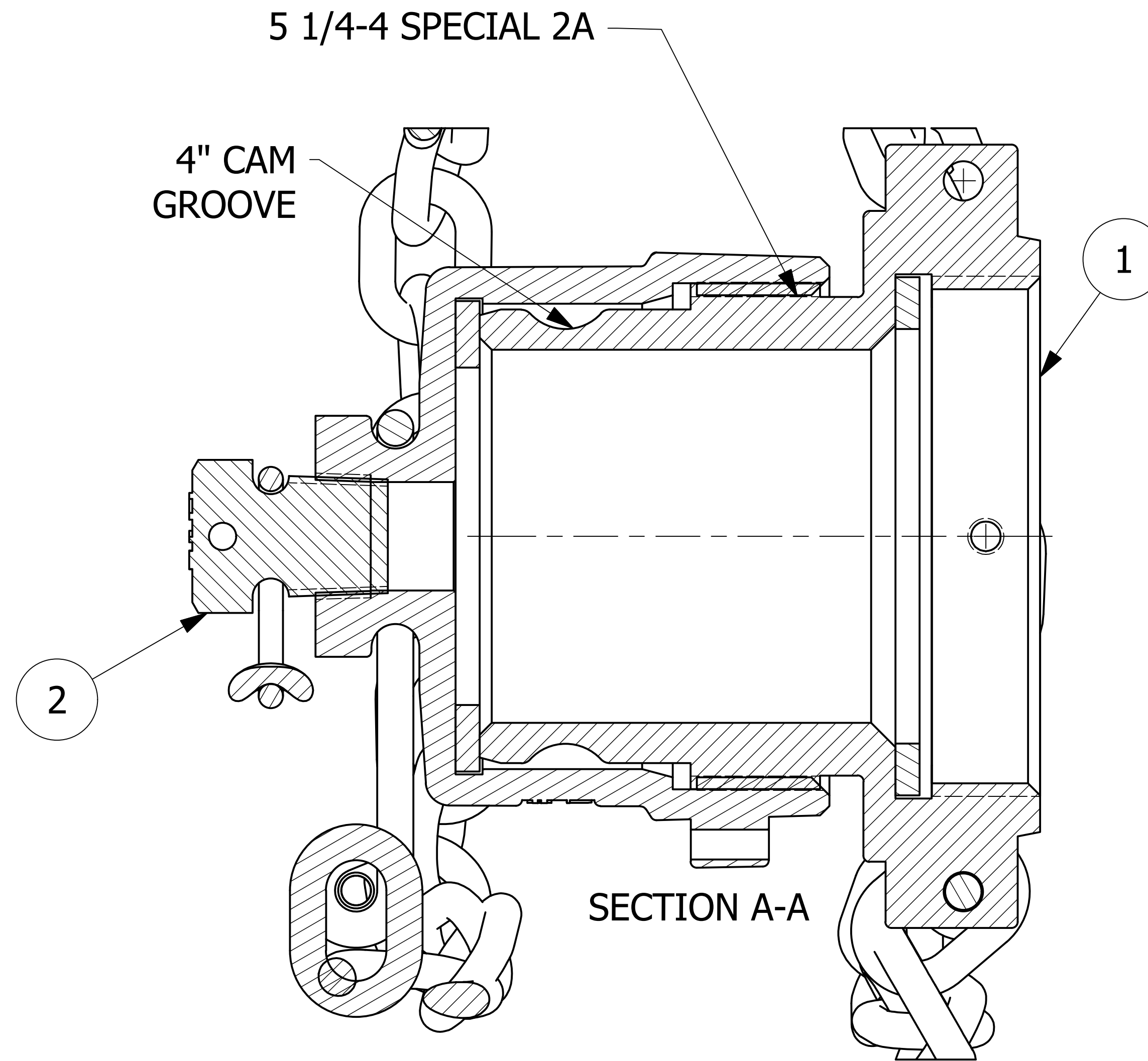
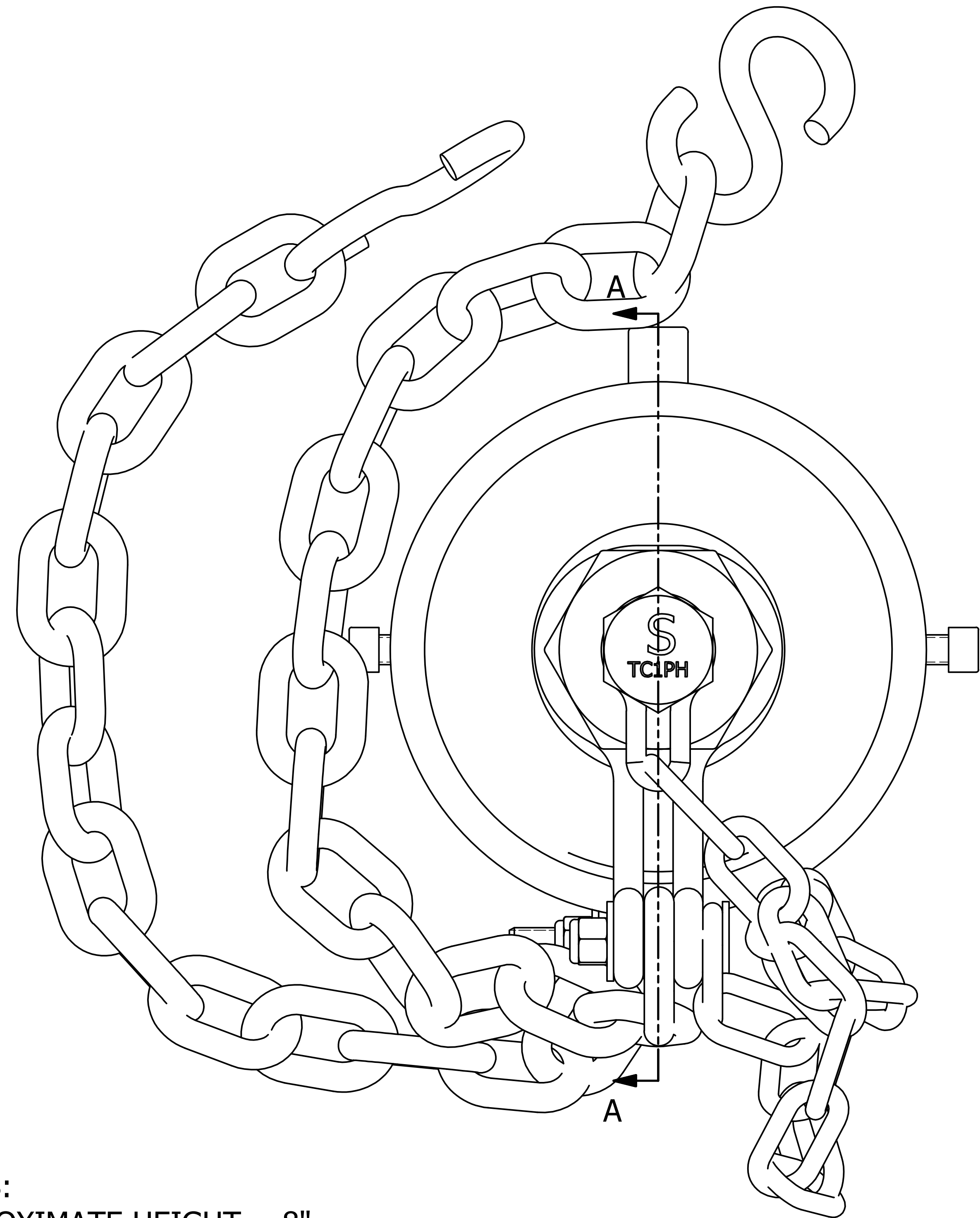

NOTES:

1. APPROXIMATE HEIGHT = 8"
2. AAR APPROVAL # E-149523.
3. THIS ASSEMBLY IS AAR AND DOT APPROVED.
4. QUICK DISCONNECT MEETS A-A-59326D SPECS.
5. GASKETS ARE WHITE NITRILE.
6. SPRAY WITH UDSA APPROVED WHITE MINERAL OIL OR VEGETABLE OIL AS A RUST INHIBITOR.

C	WEB	12/15/21	ADDED SPRAY NOTE; UPDATED TITLE BLOCK
B	WEB	4/6/15	A-A-59326D WAS MIL-C-27487G, E-149523 WAS E-049013
A	BG	2/14/13	DRAWING RELEASED FOR PRODUCTION
REV	BY	DATE	DESCRIPTION

UNLESS OTHERWISE SPECIFIED DIMENSIONAL TOLERANCES	DRAWN BY:	CHL
FRACTIONAL: ±1/16	CHECKED BY:	TAJ
X.XX: ±.03	PROTOTYPE DATE:	5/24/2012
X.XXX: ±.015	APPROVED FOR PRODUCTION BY:	BG
ANGULAR: ±1°	PRODUCTION DATE:	2/14/2013
DEBURR ALL SHARP EDGES. ALL MACHINED SURFACES TO HAVE A 125 RMS FINISH UNLESS NOTED OTHERWISE.	SIZE:	D
THIRD ANGLE PROJECTION	DRAWING #:	33280

SALCO PRODUCTS, INC.		
PART NAME: QUICK CONNECT 4" THREAD ON		
MATERIAL: SEE BOM		
PROJECT #:	120524	SHEET #:
PART #:		SCALE: 1:1
TE4IU2A		