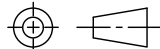

NOTES:

1. MATERIAL IS DUPONT U2A S26/G26 CERTIFIED BLACK VITON® GF-600S DURO 75±5 SHORE A
2. MUST FOLLOW Q-2.14.1.

REV	BY	DATE	DESCRIPTION
I	JAO	6/21/21	ADDED NOTE MUST FOLLOW Q-2.14.1.
H	KHK	9/4/13	UPDATED MATERIAL NOTE, TITLEBLOCK
G	BRG	5/8/08	REMOVED CHART & MAT'L WAS VITON GF

<small>UNLESS OTHERWISE SPECIFIED DIMENSIONAL TOLERANCES</small> FRACTIONAL: ±1/16 X.XX: ±.03 X.XXX: ±.015 ANGULAR: ±1° DEBURR ALL SHARP EDGES. ALL MACHINED SURFACES TO HAVE A 125 RMS FINISH UNLESS NOTED OTHERWISE. THIRD ANGLE PROJECTION 	DRAWN BY:	CLH
	CHECKED BY:	
	PROTOTYPE DATE:	6/15/2021
	APPROVED FOR PRODUCTION BY:	CLH
	PRODUCTION DATE:	2/6/1998
	SIZE:	A
	DRAWING #:	24601

SALCO PRODUCTS, INC.		
PART NAME: QI RUPTURE DISK GASKET		
MATERIAL: SEE NOTE		
PROJECT #: 940801	SHEET #: 1 OF 1	SCALE: 1:1
PART #: QI261RDG12		