

NO.	PART NAME	PART#	REQ'D	MATERIAL
1	SHEET 3"	SHT3UHR	1.44 SQ FT	SALCO PE
2	PARALLEL INSTRUMENT TEE PLUG	HSPITPLG3	1	SALCO PE

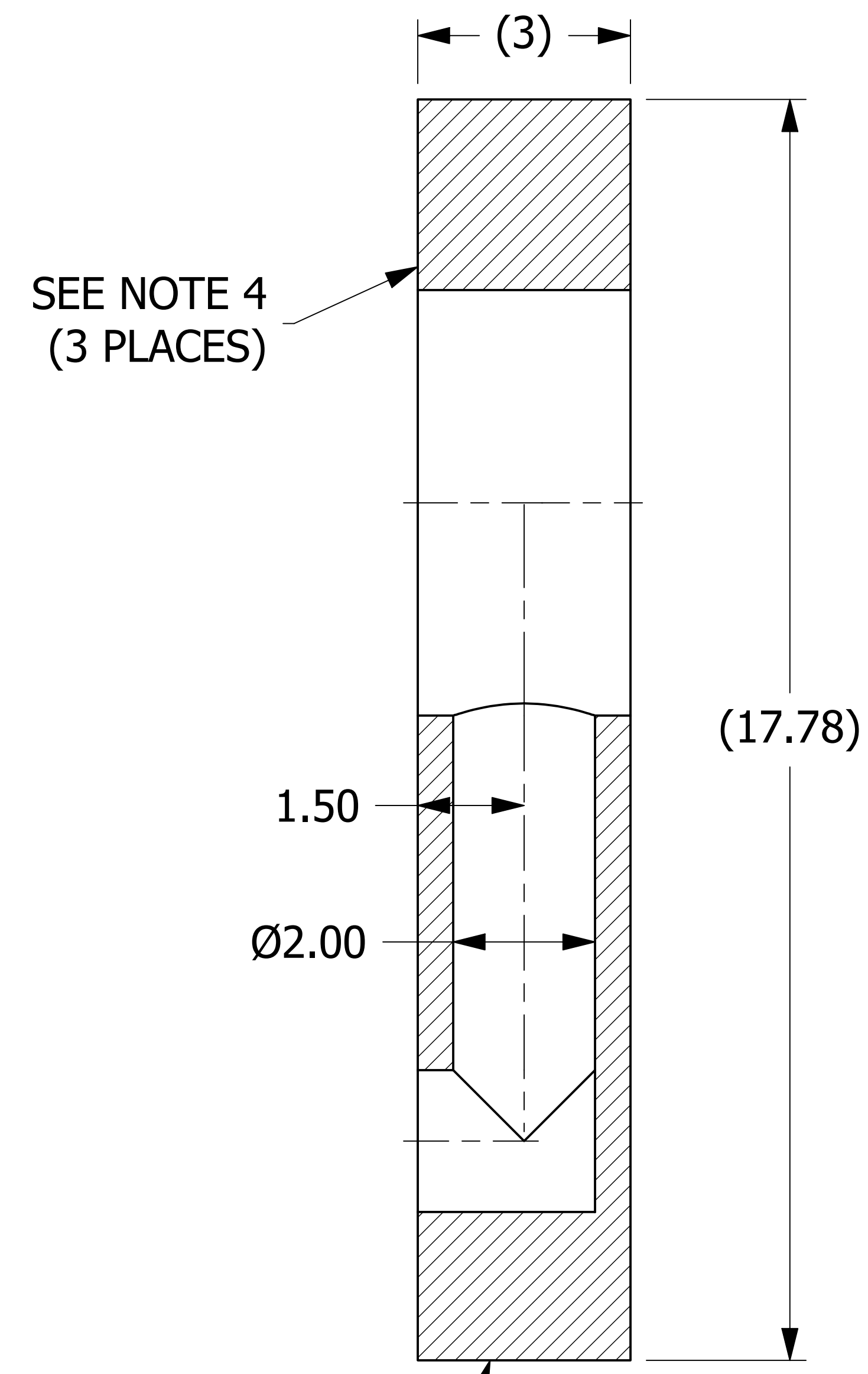
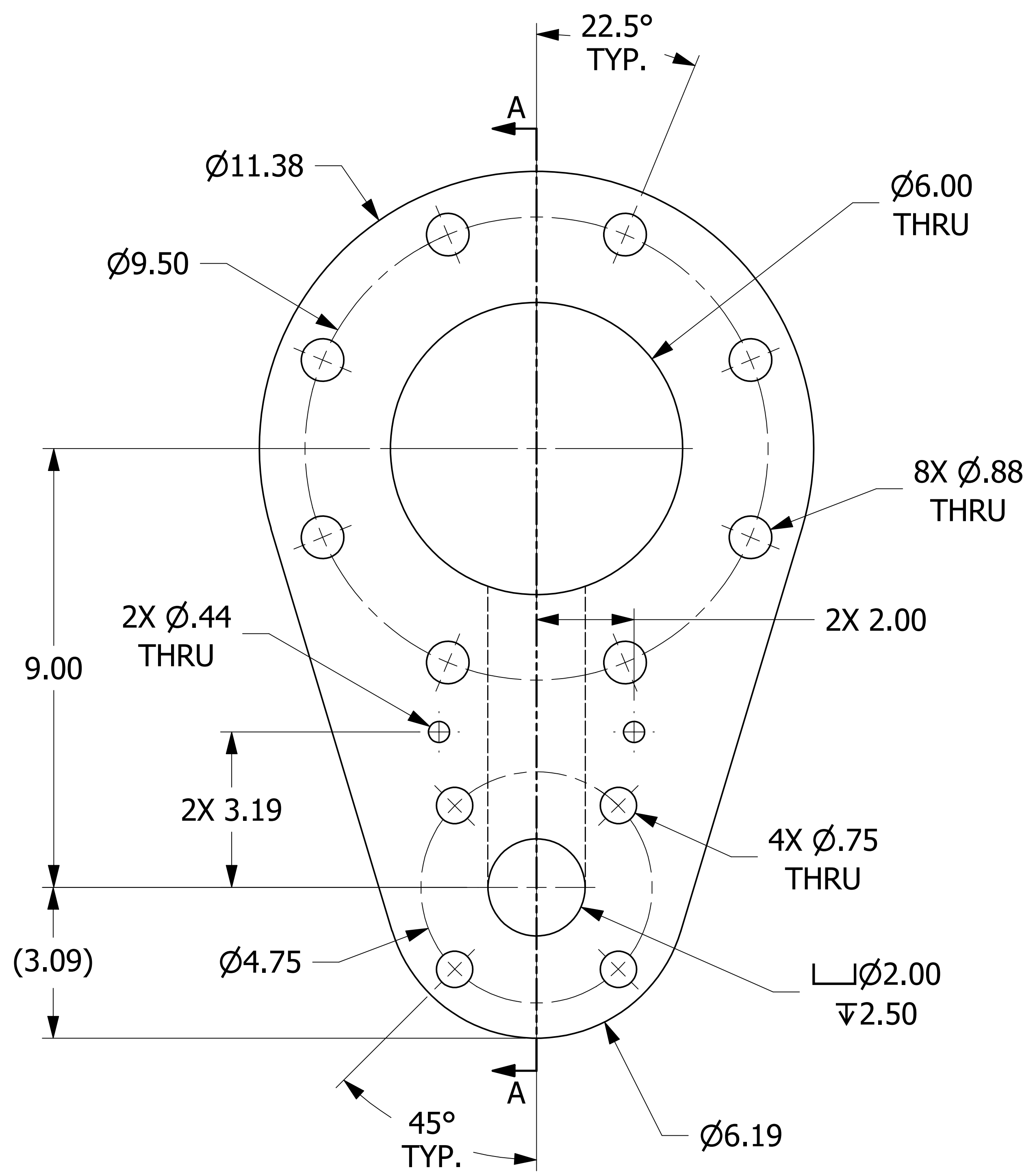

MARK PER QAP5A-1
TEXT HEIGHT .1" MIN.

SECTION A-A

- NOTES:
1. SEE DOCUMENT DSS 1 FOR MATERIAL SPECIFICATIONS.
 2. SEE DOCUMENT QAP5A-1 FOR MARKING PROCEDURE.
 3. SEE DOCUMENT DSS 3 FOR FRICTION WELDING SPECIFICATIONS.
 4. SEE DOCUMENT DSS 5 FOR SERRATED GASKET SURFACE SPECIFICATIONS.
 5. AAR APPROVAL #E-099017.

REV	BY	DATE	DESCRIPTION
C	WEB	10-15-14	ADDED DSS 3 AND DSS 5
B	KHK	1-30-13	UPDATED TO CURRENT DRAFT STANDARDS, NOTE, BOM
A	GDS	7-20-11	NEW DRAWING ADDED TO SYSTEM

UNLESS OTHERWISE SPECIFIED DIMENSIONAL TOLERANCES	DRAWN BY:	VD
FRACTIONAL: ±1/16	CHECKED BY:	WRB
X.XX: ±.03	PROTOTYPE BY:	VD
X.XXX: ±.015	PROTOTYPE DATE:	5/25/2011
ANGULAR: ±1°	APPROVED FOR PRODUCTION BY:	VD
DEBURR ALL SHARP EDGES. ALL MACHINED SURFACES TO HAVE A 125 RMS FINISH UNLESS NOTED OTHERWISE.	PRODUCTION DATE:	7/22/2011
THIRD ANGLE PROJECTION		

SALCO PRODUCTS, INC.

PART NAME: **PARALLEL INSTRUMENT TEE 6"X2"**

MATERIAL: **SEE BOM/NOTE**

PROJECT #: **110525** SHEET #: **1 OF 1** SCALE: **5:8**

DRAWING #: **D30901** PART #: **HSPIT6X2**