

NO.	PART NAME	PART #	REQ'D	MATERIAL
1	PARALLEL INSTRUMENT TEE PLUG	HSPITPLG3	1	SALCO PE
2	SHEET 3"	SHT3UHR	.96 SQ FT	SALCO PE

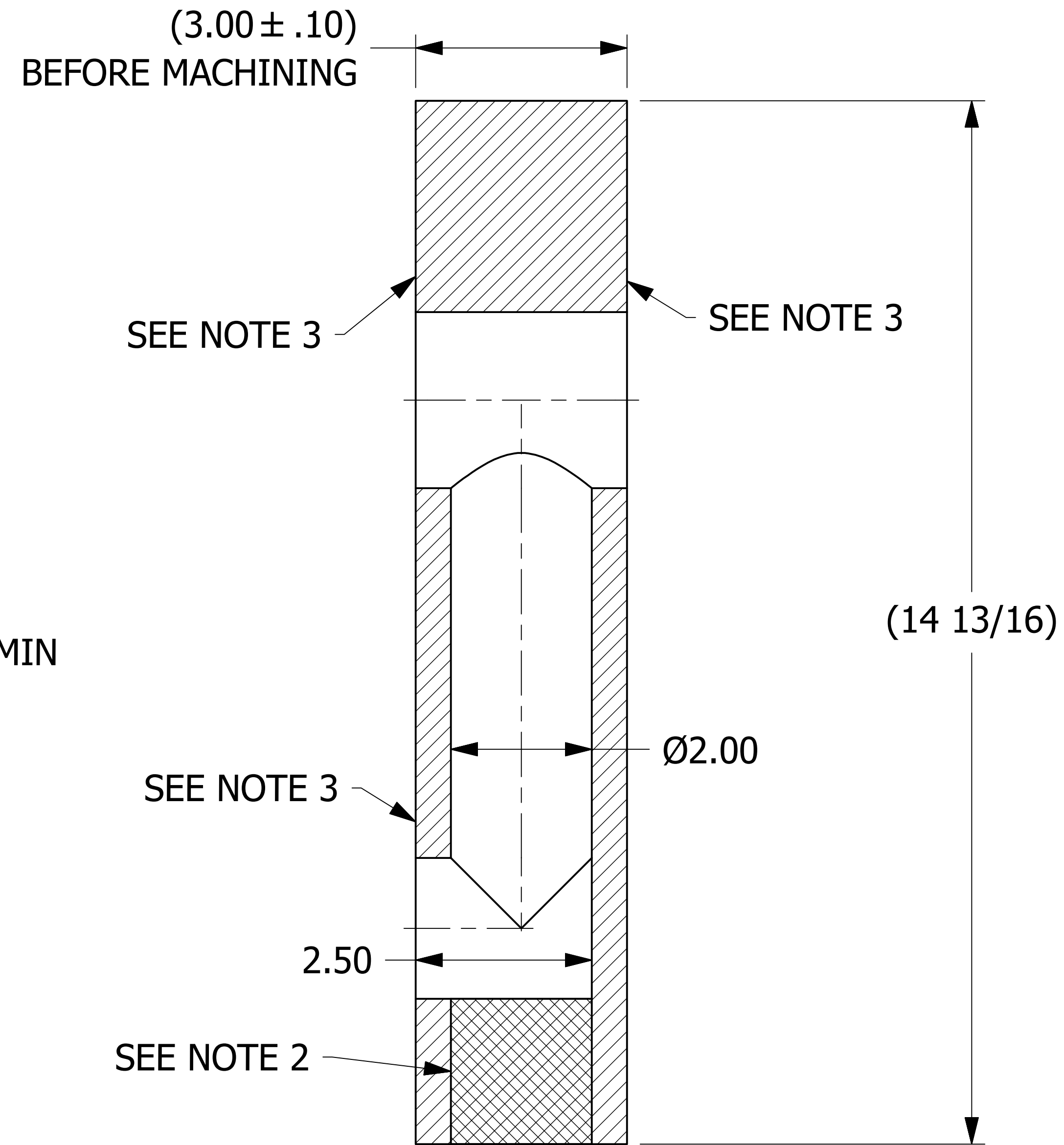
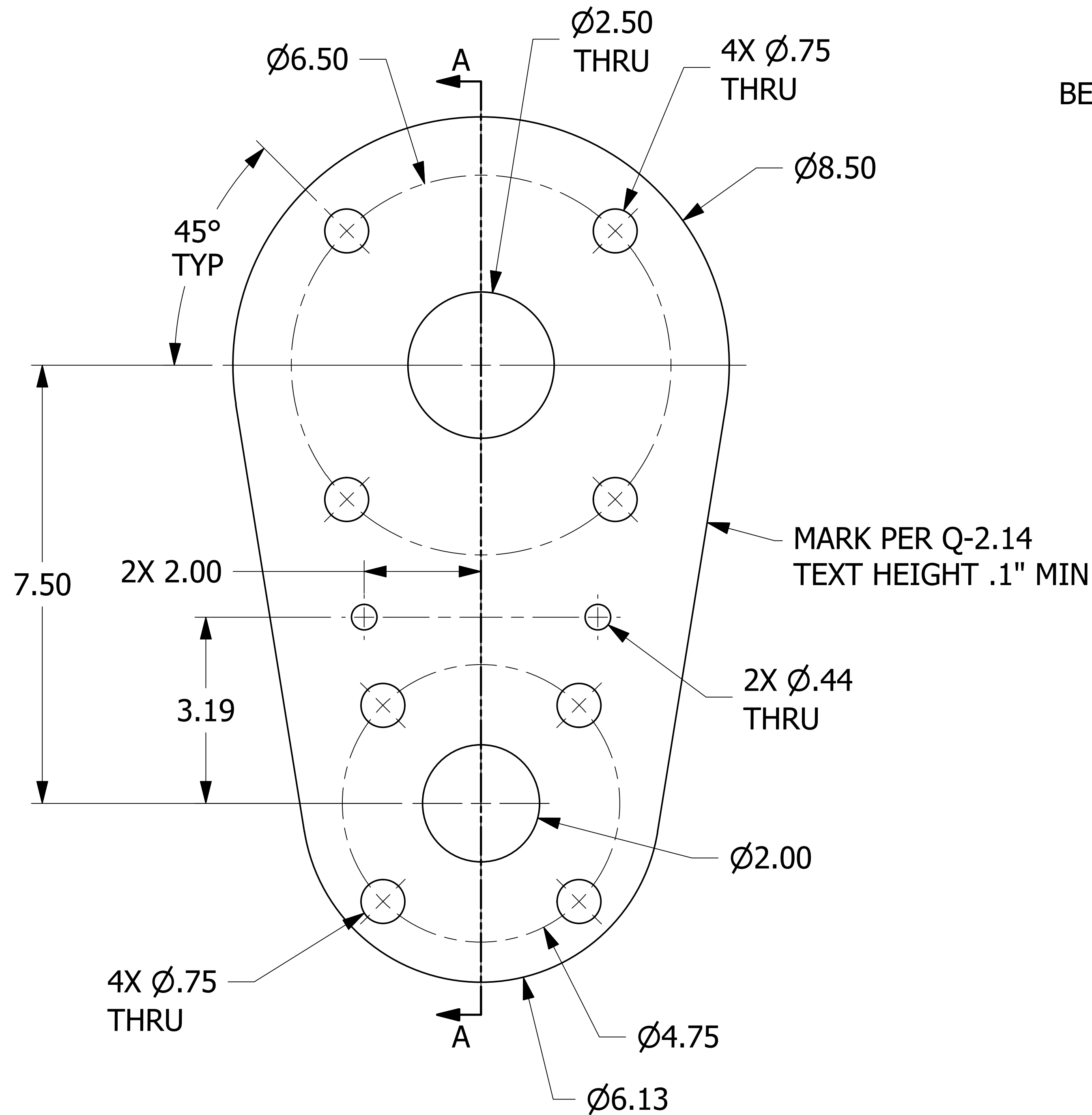

SECTION A-A

REV	BY	DATE	DESCRIPTION
C	TAK	9/14/20	UPDATED TITLEBLOCK, AAR #, Q-2.14 WAS QAP5A-1; ADDED DSS 3 & 5
B	KHK	1/30/13	UPDATED TITLEBLOCK, CURRENT DRAFT STANDARDS
A	BRG	5/24/11	NEW PART ADDED TO THE NETWORK

NOTES:

1. SEE DOCUMENT DSS 1 FOR MATERIAL SPECIFICATIONS.
2. SEE DOCUMENT DSS 3 FOR FRICTION WELDING SPECIFICATIONS.
3. SEE DOCUMENT DSS 5 FOR SERRATED GASKET SPECIFICATIONS.
4. SEE DOCUMENT Q-2.14 FOR MARKING PROCEDURE.
5. AAR APPROVAL #E-202143.

UNLESS OTHERWISE SPECIFIED DIMENSIONAL TOLERANCES	DRAWN BY:	WRB
FRACTIONAL: $\pm 1/16$	CHECKED BY:	AJB
X.XX: $\pm .03$	PROTOTYPE DATE:	4/1/2011
X.XXX: $\pm .015$	APPROVED FOR PRODUCTION BY:	AJB
ANGULAR: $\pm 1^\circ$	PRODUCTION DATE:	5/24/2011
DEBURR ALL SHARP EDGES. ALL MACHINED SURFACES TO HAVE A 125 RMS FINISH. UNLESS NOTED OTHERWISE. THIRD ANGLE PROJECTION	SIZE:	D
	DRAWING #:	30533

SALCO PRODUCTS, INC.

PART NAME: **PARALLEL INSTRUMENT TEE 3" X 2"**

MATERIAL: **SEE BOM/NOTE**

PROJECT #: **110401** SHEET #: **1 OF 1** SCALE: **3:4**

PART #: **HSPIT3VX2**