

NO.	PART NAME	PART#	REQ'D	MATERIAL
1	QUICK CONNECT ADAPTER 2" THREAD ON	K2SMPA	1	316 SS
2	QUICK CONNECT CAP 2" KAMMED	K2SDC3A	1	316 SS

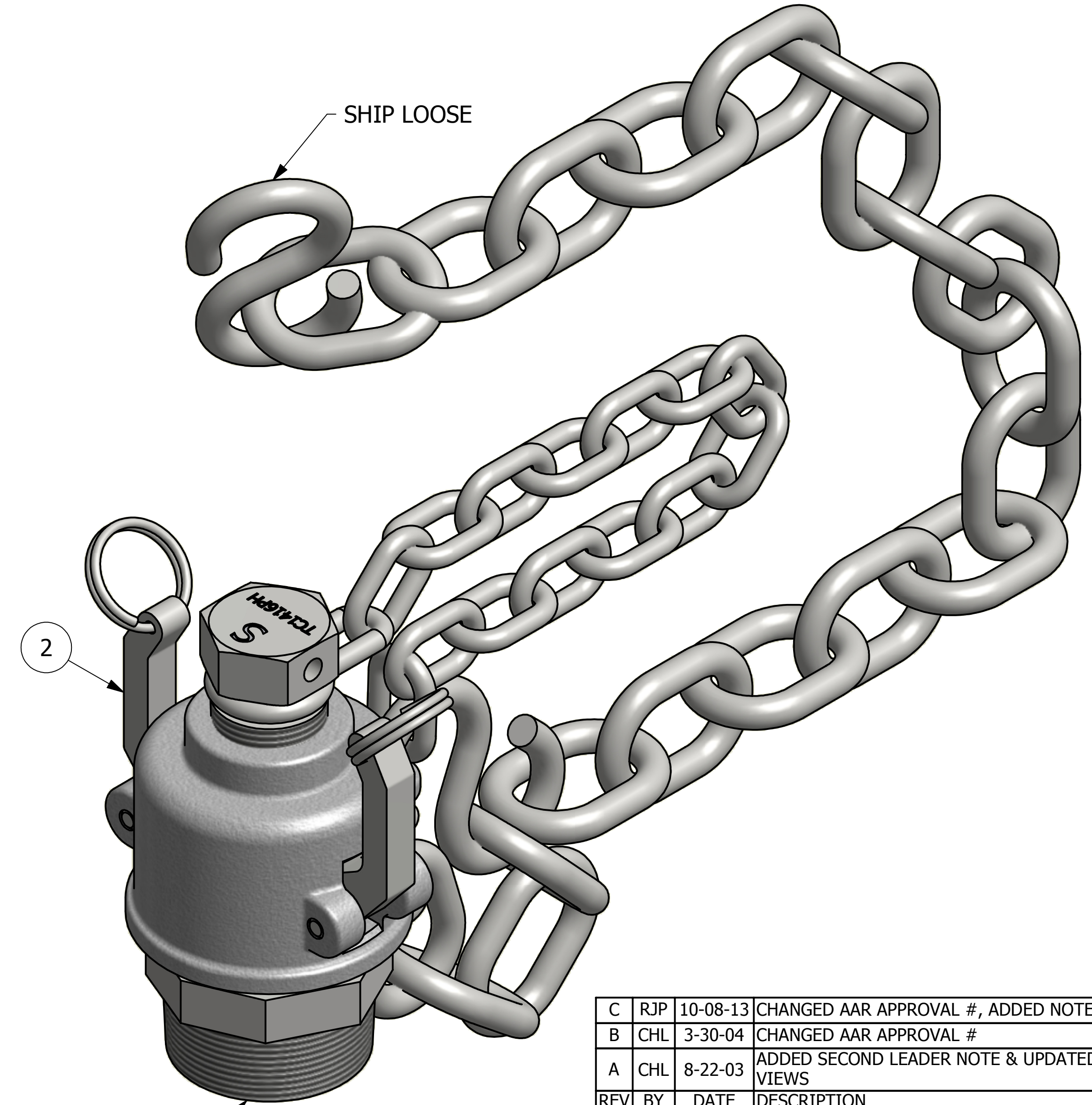
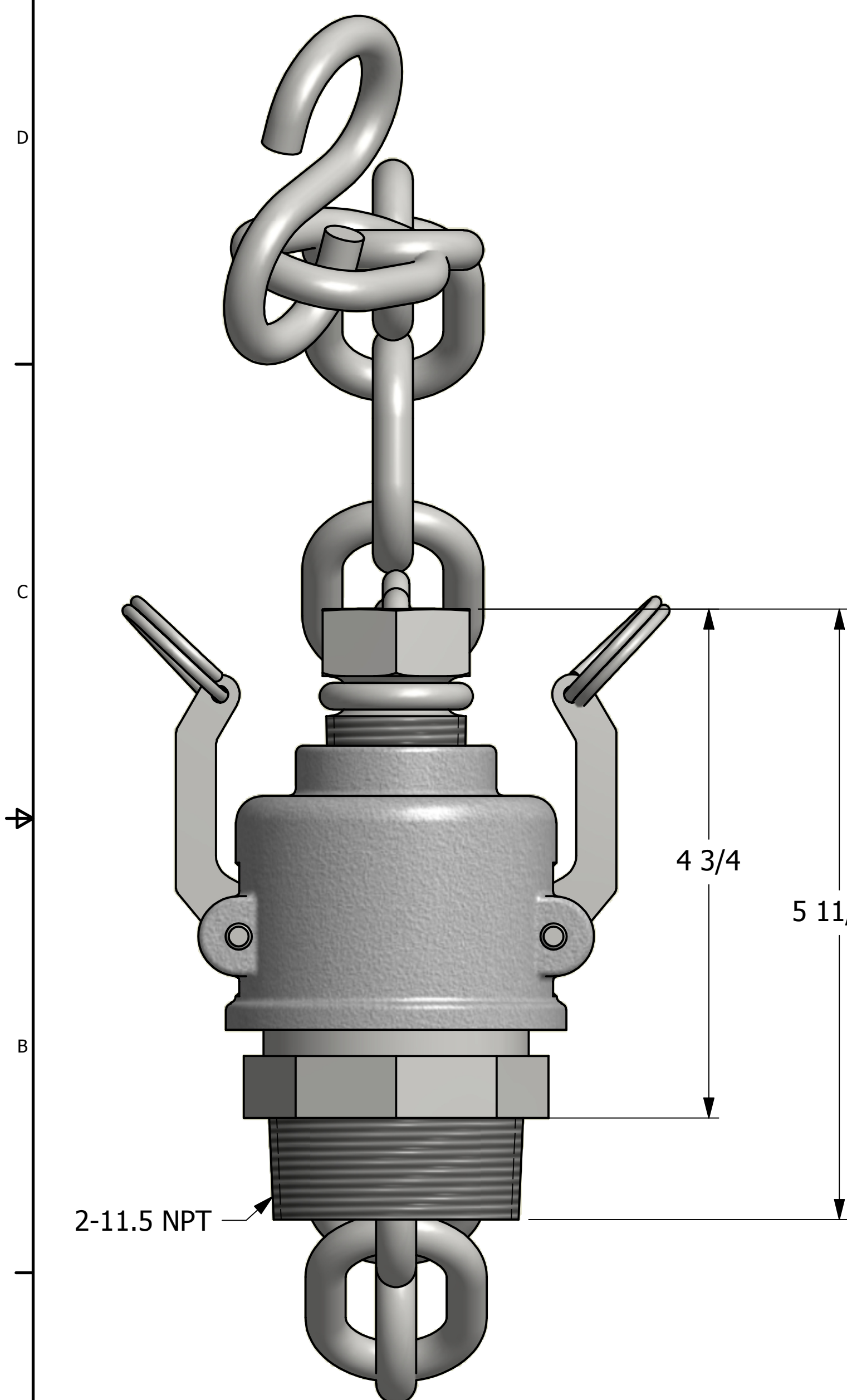

- NOTES:
- HARDWARE IS SS.
 - GASKET IS BLACK EPDM.
 - AAR APPROVAL # E-139514.

REV	BY	DATE	DESCRIPTION
C	RJP	10-08-13	CHANGED AAR APPROVAL #, ADDED NOTES
B	CHL	3-30-04	CHANGED AAR APPROVAL #
A	CHL	8-22-03	ADDED SECOND LEADER NOTE & UPDATED VIEWS

UNLESS OTHERWISE SPECIFIED DIMENSIONAL TOLERANCES	DRAWN BY:	ACC
FRACTIONAL: ±1/16	CHECKED BY:	ACC
X.XX: ±.03	PROTOTYPE BY:	ACC
X.XXX: ±.015	PROTOTYPE DATE:	2/19/2003
ANGLE: ±1°	APPROVED FOR PRODUCTION BY:	ACC
THIS PRINT, PROPERTY OF SALCO PRODUCTS INC, CONTAINS PROPRIETARY INFORMATION AND MUST NOT BE COPIED, REPRODUCED, OR USED DETRIMENTALLY TO OUR INTEREST.	PRODUCTION DATE:	2/19/2003
THIRD ANGLE PROJECTION		

SALCO PRODUCTS, INC.

PART NAME:
QUICK CONNECT 2" THREAD ON

MATERIAL: **SEE BOM**

PROJECT #: _____ SHEET #: **1 OF 1** SCALE: **1:1**

DRAWING #: **C17677** PART #: **K2SUMP3A**

