

NO	PART NAME	PART#	REQ'D	MATERIAL
1	HUCK RIVET 1/4"X13/16"	A16204	1	304 SS
2	EYEBOLT 7/8"X6"	EBR786HS6R	1	316 SS
3	HEAVY HEX NUT 7/8"-9	N78XS6H	1	416 SS
4	FLAT WASHER 7/8" SAE	WASH78S6	1	316 SS

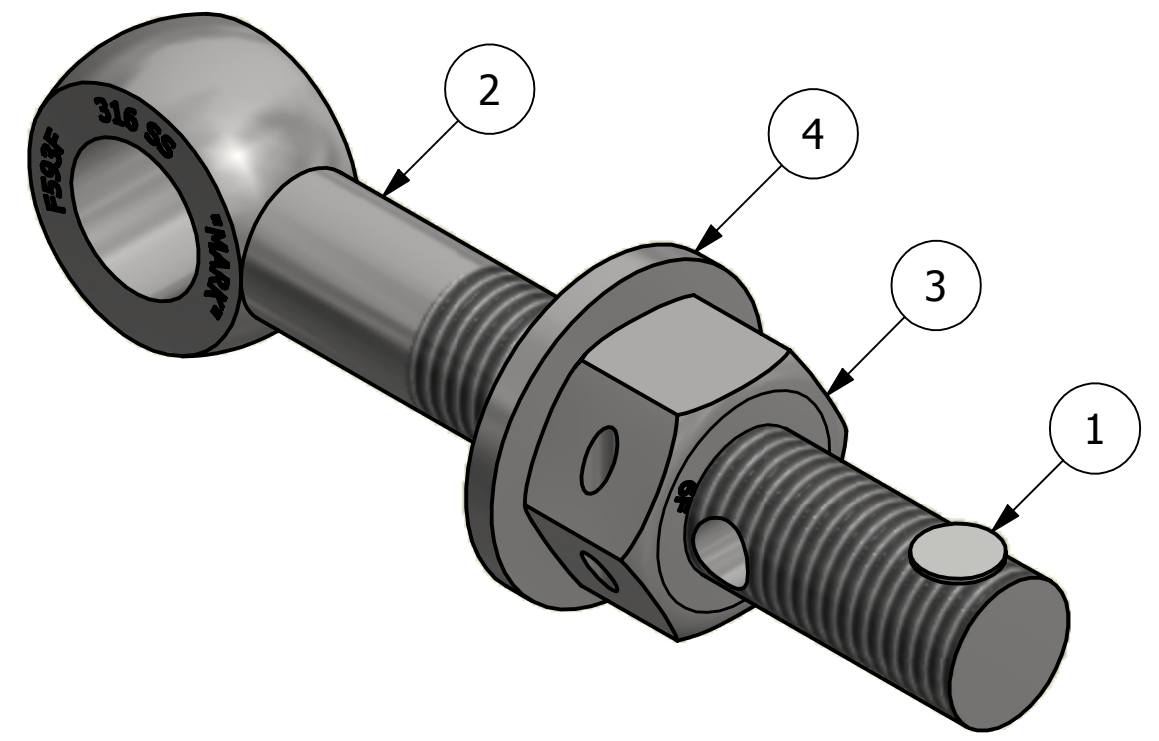

ISOMETRIC VIEW

REV	BY	DATE	DESCRIPTION
B	RJP	7-14-17	WASH78S6 WAS WASH78S4; UPDATED TO CURRENT STANDARDS
A	CHL	11-17-03	REPLACED N78XHS6 W/ N78XS6H

UNLESS OTHERWISE SPECIFIED DIMENSIONAL TOLERANCES	DRAWN BY:	CHL
FRACTIONAL: ±1/16	CHECKED BY:	SAB
X.XX: ±.03	PROTOTYPE BY:	CHL
X.XXX: ±.015	PROTOTYPE DATE:	2/6/2002
ANGULAR: ±1°	APPROVED FOR PRODUCTION BY:	SAB
DEBURR ALL SHARP EDGES. ALL MACHINED SURFACES TO HAVE A 125 RMS FINISH UNLESS NOTED OTHERWISE.	PRODUCTION DATE:	2/6/2002
THIRD ANGLE PROJECTION		

SALCO PRODUCTS, INC.

PART NAME: **EYEBOLT ASSEMBLY 7/8"X6"**

MATERIAL: **SEE BOM**

PROJECT #: _____ SHEET #: **1 OF 1** SCALE: **1:1**

DRAWING #: **B16671** PART #: **EB786XHHAS6**

THIS PRINT, PROPERTY OF SALCO PRODUCTS INC., CONTAINS PROPRIETARY INFORMATION AND MUST NOT BE COPIED, REPRODUCED, OR USED DETRIMENTALLY TO OUR INTEREST.