

NO.	PART NAME	PART #	REQ'D	MATERIAL
1	EYEBOLT 7/8"X6"	EBR786S6R	1	316 SS
2	HEAVY SQUARE NUT 7/8"-9	N78S6	1	416 SS
3	FLAT WASHER 7/8" SAE	WASH78S6	1	316 SS
4	HUCK RIVET 1/4"X13/16"	A16204	1	304 SS

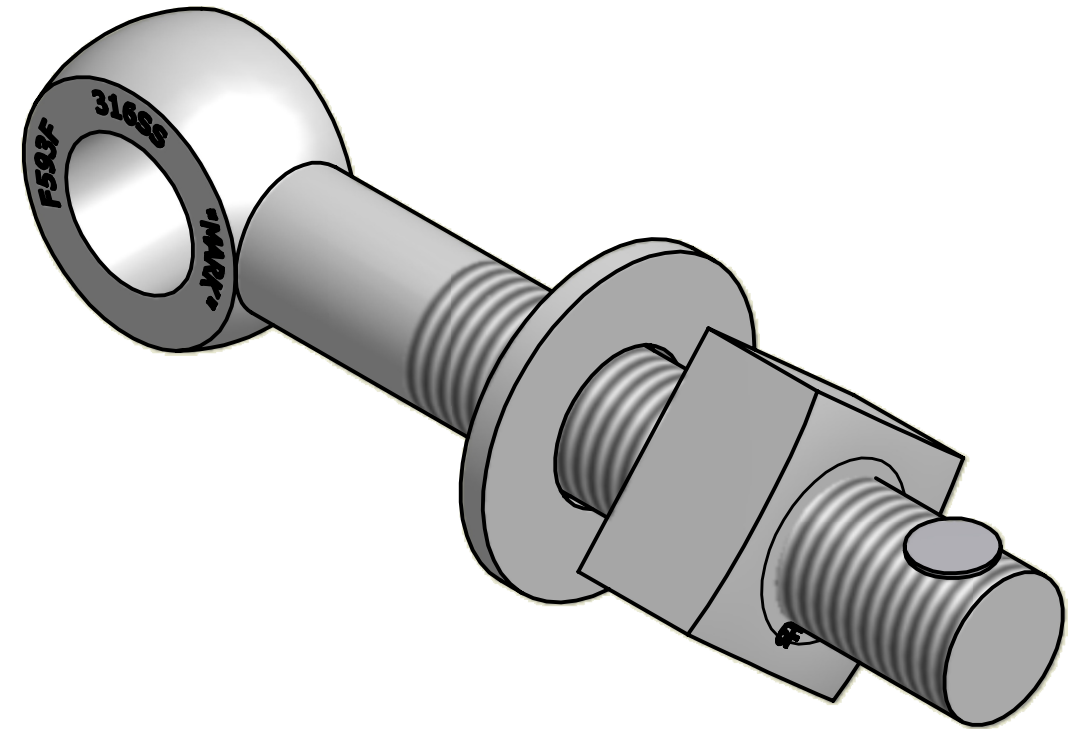

ISOMETRIC VIEW

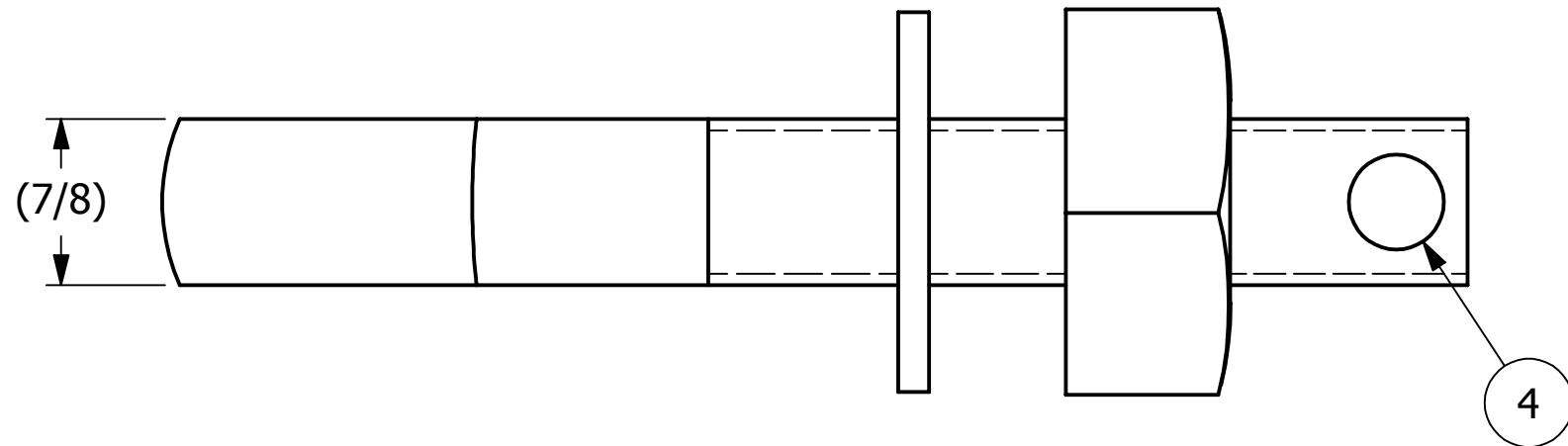
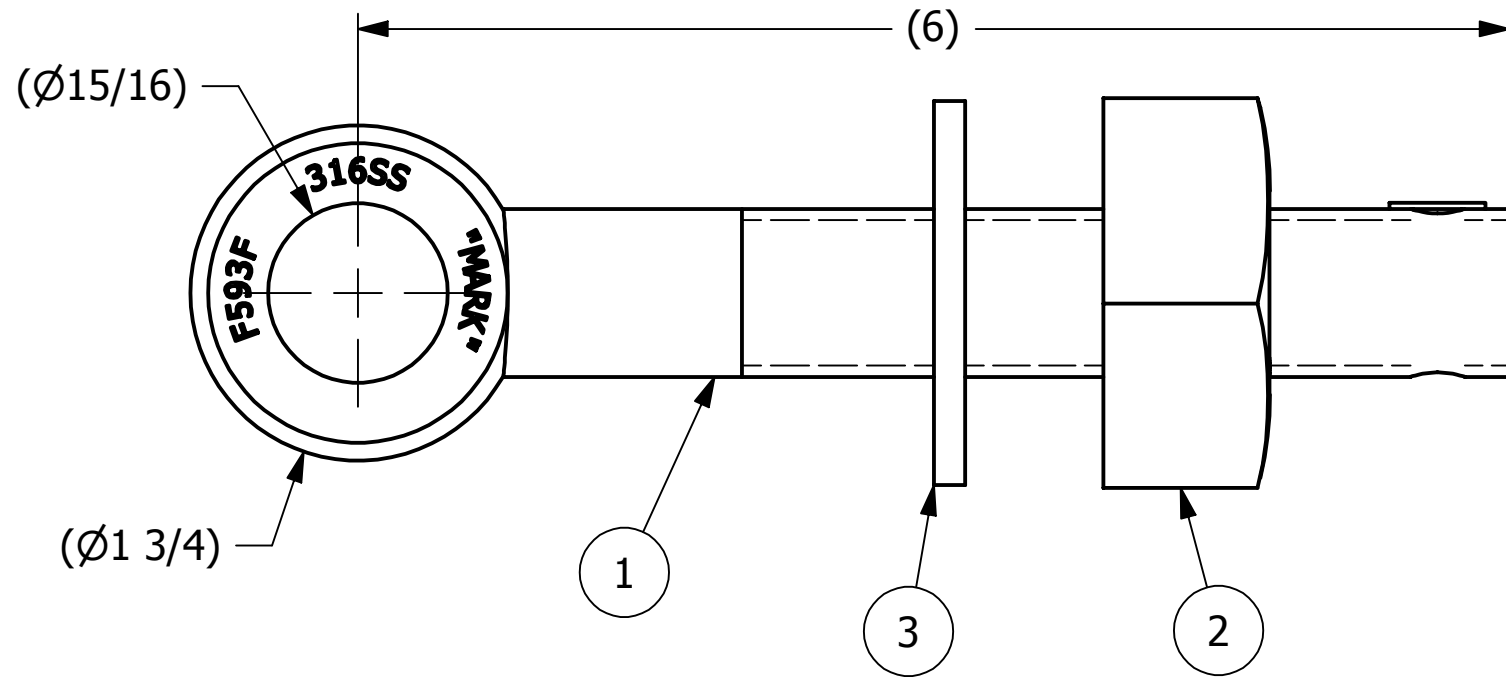

A	CHL	11-26-01	REPLACED SN14S W/ A16204
REV	BY	DATE	DESCRIPTION

<small>UNLESS OTHERWISE SPECIFIED DIMENSIONAL TOLERANCES</small> FRACTIONAL: ±1/16 X.XX: ±.03 X.XXX: ±.015 ANGULAR: ±1° <small>DEBURR ALL SHARP EDGES. ALL MACHINED SURFACES TO HAVE A 125 RMS FINISH UNLESS NOTED OTHERWISE.</small> <small>THIRD ANGLE PROJECTION</small>	DRAWN BY:	FOD
	CHECKED BY:	SAB
	PROTOTYPE BY:	FOD
	PROTOTYPE DATE:	6/1/1999
	APPROVED FOR PRODUCTION BY:	SAB
	PRODUCTION DATE:	6/1/1999

SALCO PRODUCTS, INC.

PART NAME: **EYEBOLT ASSEMBLY 7/8"X6"**

MATERIAL: **SEE BOM**

PROJECT #: _____ SHEET #: **1 OF 1** SCALE: **1:1**

DRAWING #: **B13502** PART #: **EB786AS6**

THIS PRINT, PROPERTY OF SALCO PRODUCTS INC., CONTAINS PROPRIETARY INFORMATION AND MUST NOT BE COPIED, REPRODUCED, OR USED DETRIMENTALLY TO OUR INTEREST.