

NO	PART NAME	PART #	REQ'D	MATERIAL
1	ID PLATE 3" X 3/4"	A15152	.5	ALUMINUM
2	DRIVE SCREW TYPE U #2 X 1/8"	DR218	2	18-8 SS
3	QUICK INSPECT FLANGE GASKET	FG5509	1	WHITE FDA PTFE
4	QUICK INSPECT SAFETY VENT	QI261BSA	1	BLACK NORYL
5	QI RETAINER GASKET	QI261DG9	1	WHITE FDA PTFE
6	RUPTURE DISC (SOLD SEPARATLEY)			

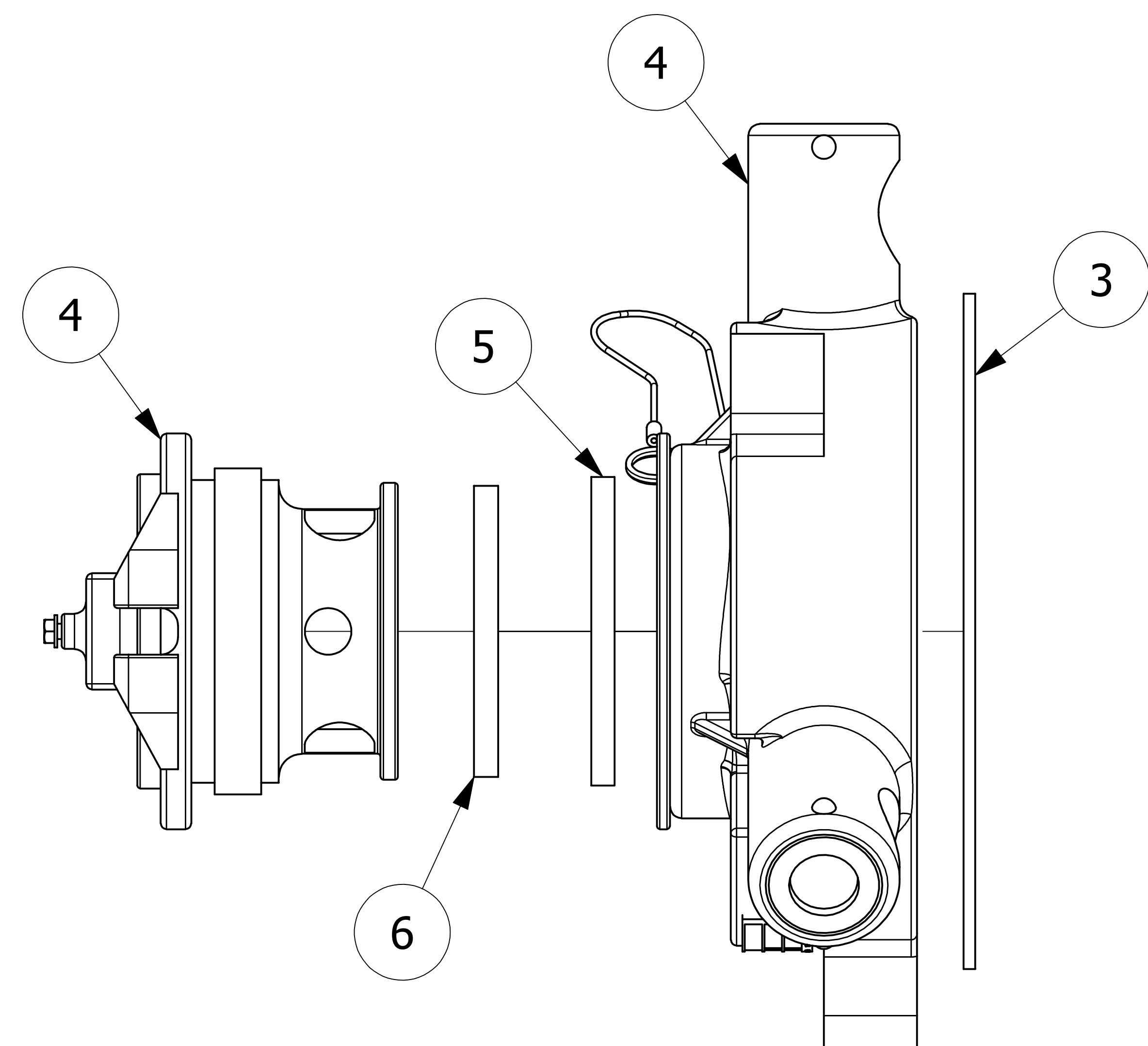
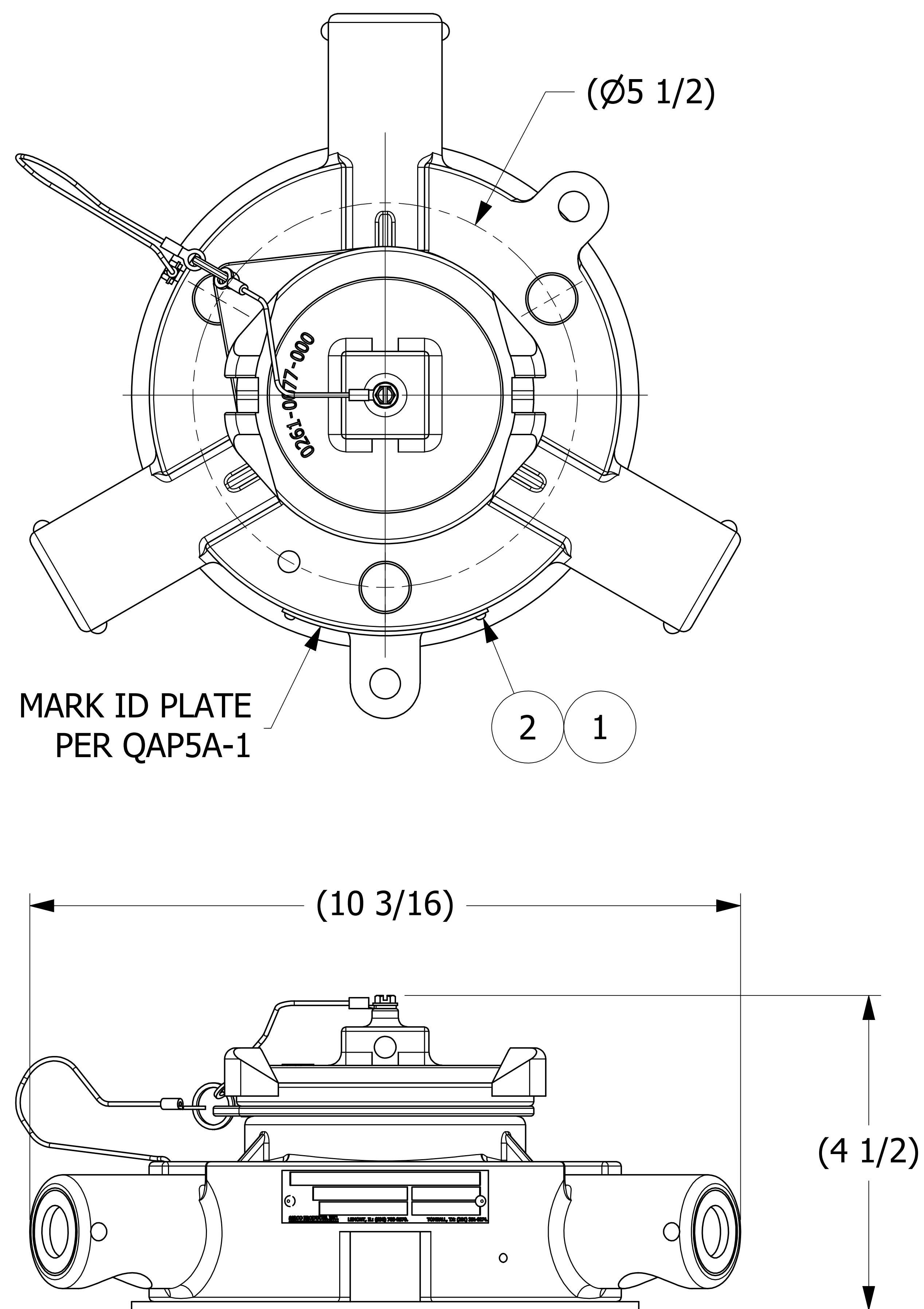

- NOTES:**
1. CUSTOMERS RESPONSIBILITY FOR COMPATIBILITY OF COMMODITY.
 2. AAR APPROVAL # PRD-162102.
 3. SEE DOCUMENT QAP5A-1 FOR MARKING PROCEDURE.
 4. FASTEN ID PLATE WITH DRIVE SCREWS.

B	JG	12-16-16	AAR APPROVAL # WAS SRD-063000
A	TAK	9-3-13	RELEASED FOR PRODUCTION
REV	BY	DATE	DESCRIPTION

UNLESS OTHERWISE SPECIFIED DIMENSIONAL TOLERANCES FRACTIONAL: ±1/16 X.XX: ±.03 X.XXX: ±.015 ANGULAR: ±1° DEBURR ALL SHARP EDGES. ALL MACHINED SURFACES TO HAVE A 125 RMS FINISH UNLESS NOTED OTHERWISE.	DRAWN BY: CHL
	CHECKED BY: PJG
	PROTOTYPE BY: CHL
	PROTOTYPE DATE: 10/2/2009
	APPROVED FOR PRODUCTION BY: PJG
THIRD ANGLE PROJECTION	PRODUCTION DATE: 8/2/2009

SALCO PRODUCTS, INC.

QUICK INSPECT SAFETY VENT

SEE BOM

PROJECT #: WAG0734 SHEET #: 1 OF 1 SCALE: 1:1

DRAWING #: E27566 PART #: QI261DG9A