

| NO. | PART NAME | PART # | REQ'D | MATERIAL |
|-----|----------------|--------|-------|----------|
| 1 | PLUG 2 1/2" | TC25P | 1 | STEEL |
| 2 | CHAIN ASSEMBLY | CH2PA | 1 | CS |

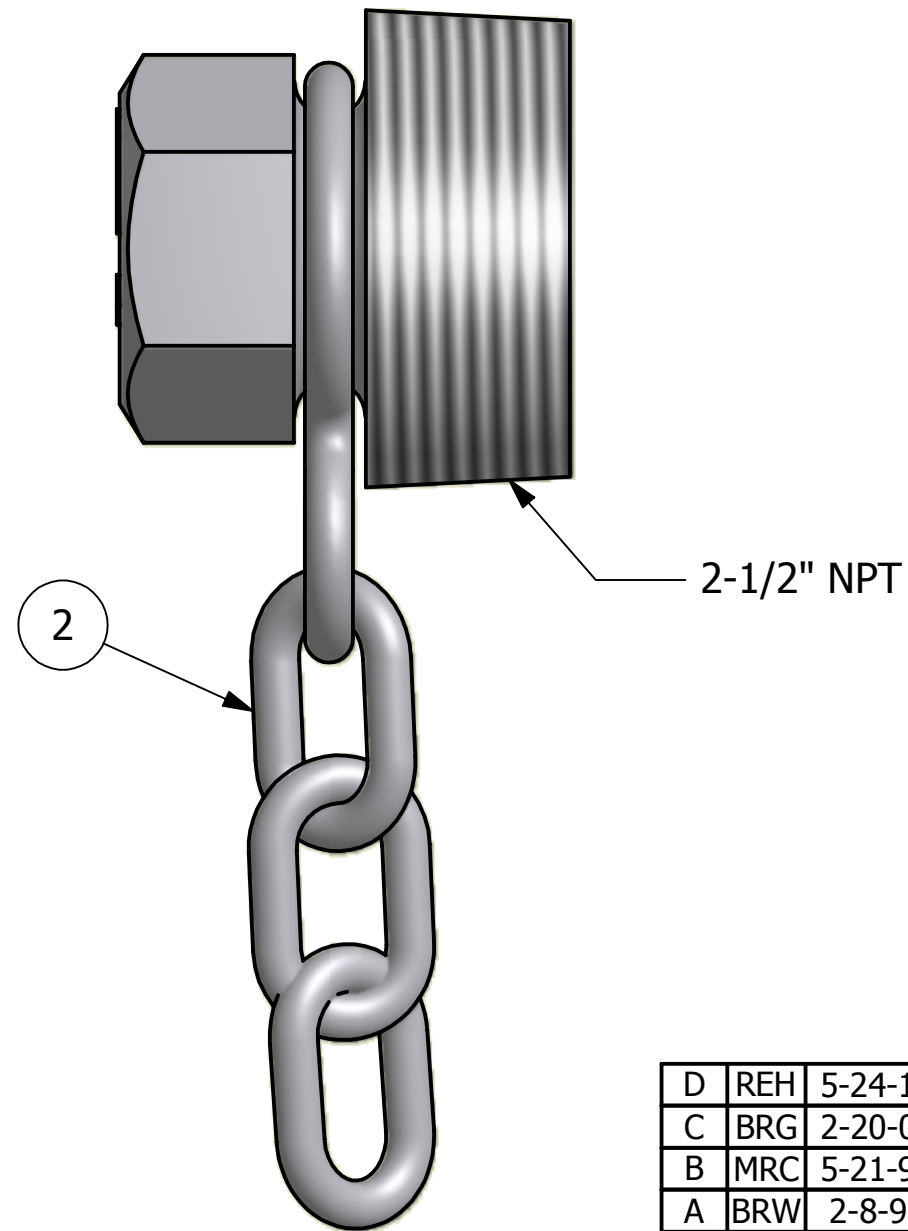
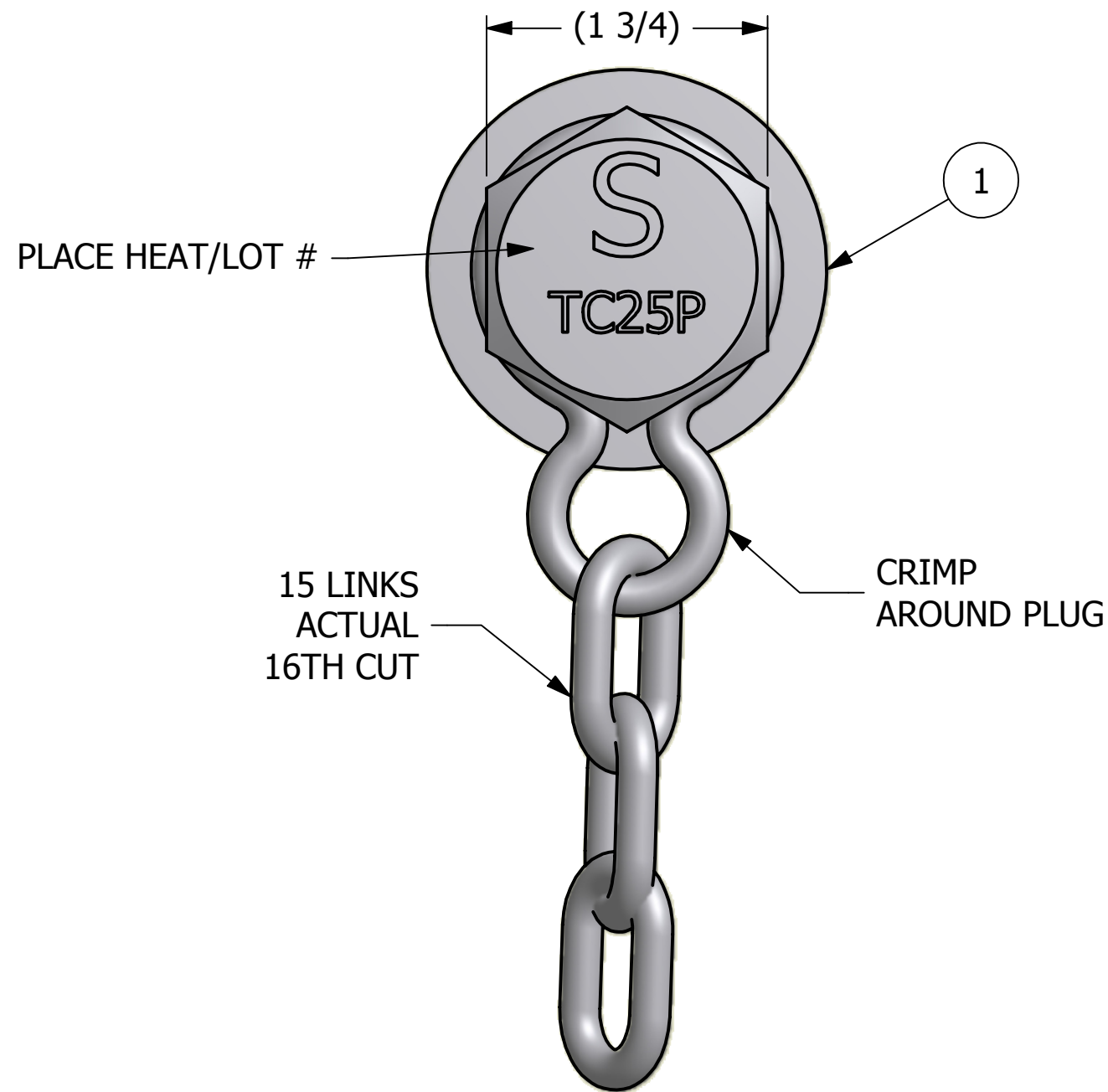

| REV | BY | DATE | DESCRIPTION |
|-----|-----|---------|----------------------------|
| D | REH | 5-24-10 | ADDED HEAT/LOT NUMBER NOTE |
| C | BRG | 2-20-08 | UPDATED PLUG MATERIAL |
| B | MRC | 5-21-97 | CHAIN DIAMETER WAS 3/16" |
| A | BRW | 2-8-96 | REMOVED MACHINE OPERATION |

| | | | |
|---|-------|-----------------------------|-----------|
| UNLESS OTHERWISE SPECIFIED DIMENSIONAL TOLERANCES | | DRAWN BY: | BRW |
| FRACTIONAL: | ±1/16 | CHECKED BY: | |
| X.XX: | ±.03 | PROTOTYPE BY: | BRW |
| X.XXX: | ±.015 | PROTOTYPE DATE: | 1/18/1996 |
| ANGULAR: | ±1° | APPROVED FOR PRODUCTION BY: | BRW |
| DEBURR ALL SHARP EDGES. ALL MACHINED SURFACES TO HAVE A 125 RMS FINISH UNLESS NOTED OTHERWISE. | | PRODUCTION DATE: | 1/18/1996 |
| THIRD ANGLE PROJECTION | | | |

| | | |
|---|--------------------------|-------------------|
| SALCO PRODUCTS, INC. | | |
| PART NAME: PLUG ASSEMBLY 2 1/2" | | |
| MATERIAL: SEE BOM | | |
| PROJECT #: | SHEET #: 1 OF 1 | SCALE: 1:1 |
| DRAWING #: B7832 | PART #: TC25PA | |

THIS PRINT, PROPERTY OF SALCO PRODUCTS INC., CONTAINS PROPRIETARY INFORMATION AND MUST NOT BE COPIED, REPRODUCED, OR USED DETRIMENTALLY TO OUR INTEREST.