

NO.	PART NAME	PART#	REQ'D	MATERIAL
1	BOTTOM OUTLET FLANGE GASKET	FG7757	1	BLACK VITON B
2	QUICK CONNECT ADAPTER 4" FLANGED	TE4IUTF	1	DUCTILE IRON

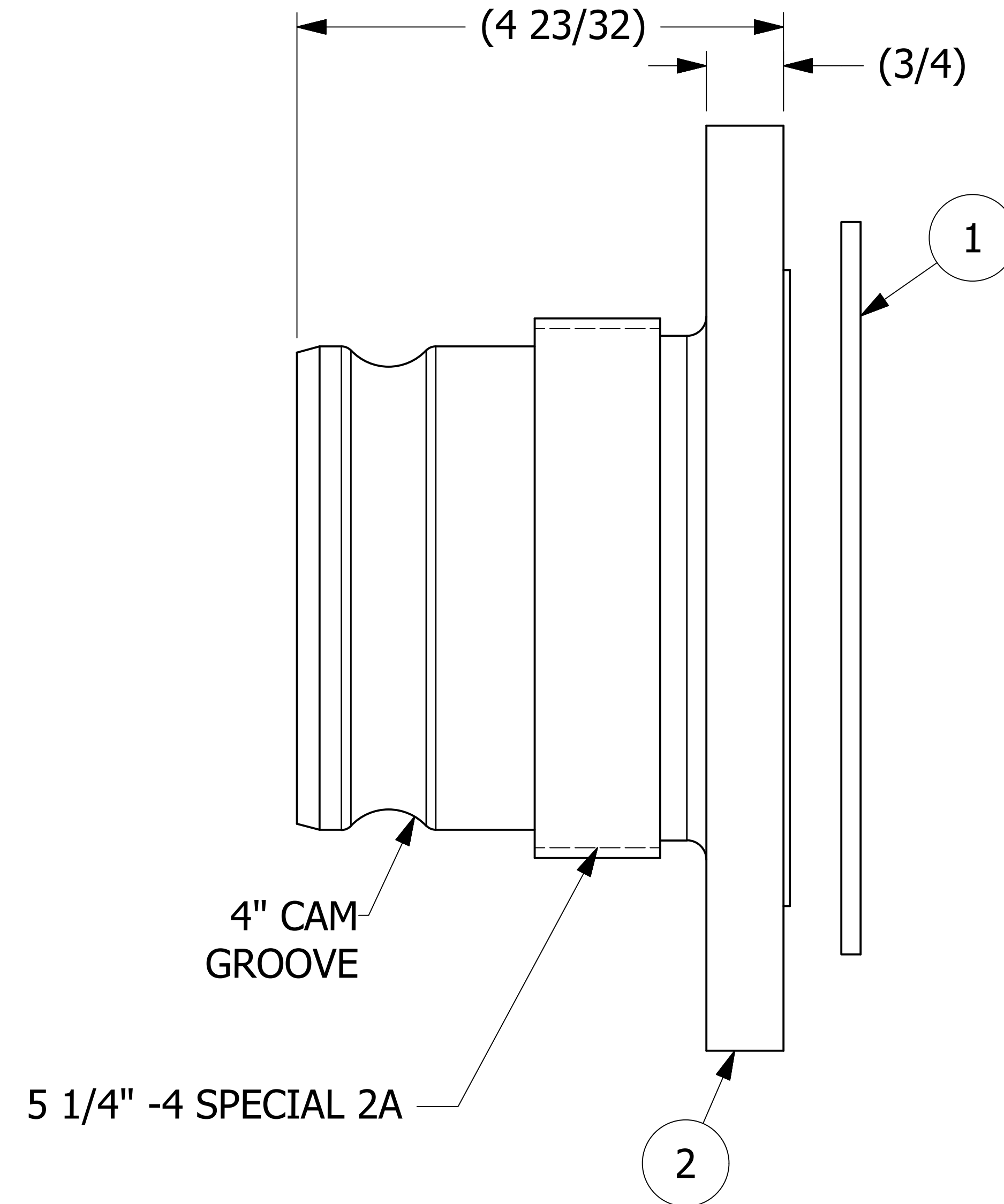
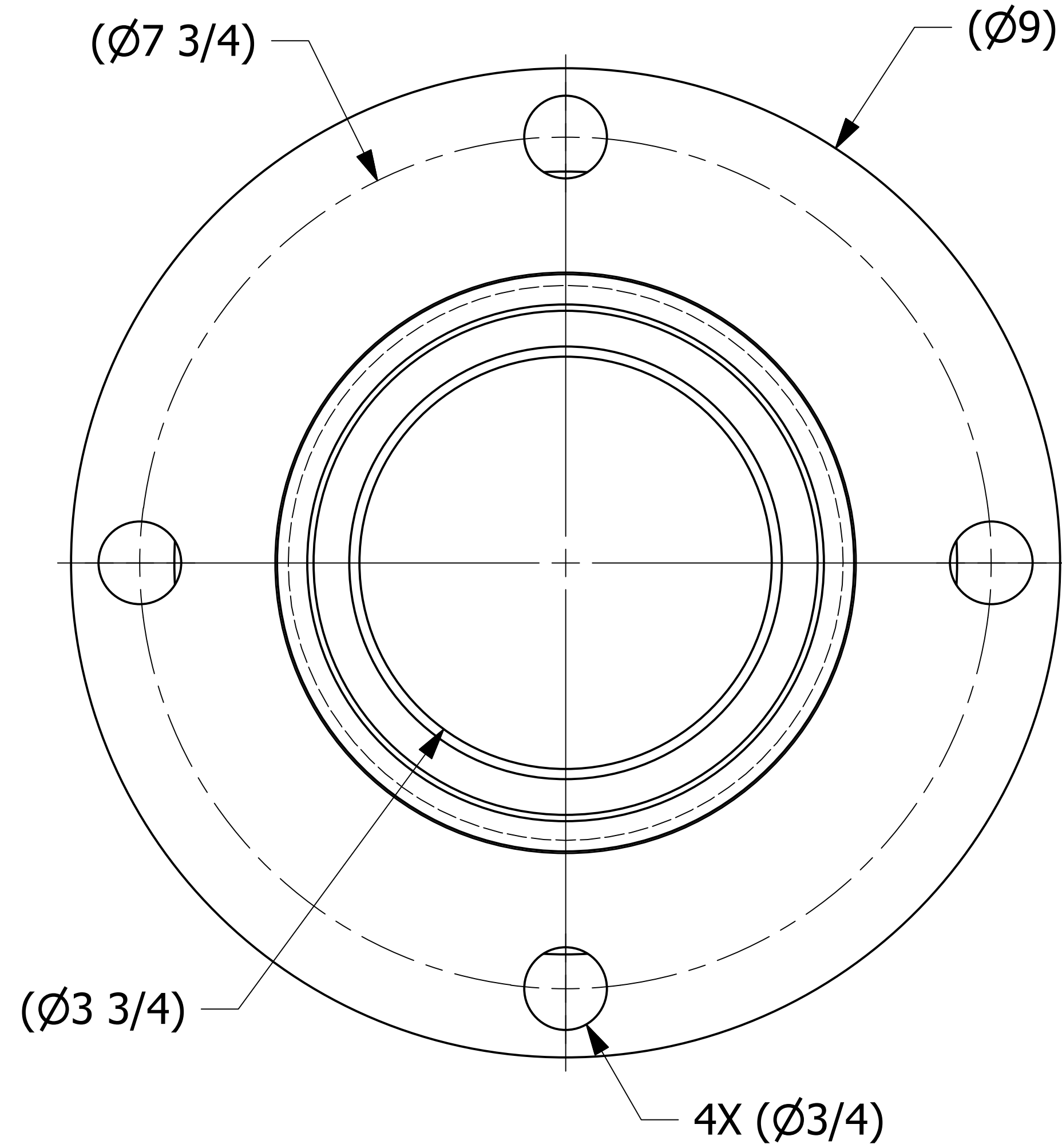

NOTES:

1. AAR APPROVAL # E-149523.
2. THIS ASSEMBLY IS AAR AND DOT APPROVED.
3. QUICK DISCONNECT MEETS A-A-59326D.
4. ADAPTER THREADS PER FIGURE E-18 IN THE AAR TANK CAR MANUAL.
5. SPRAY OR WIPE DOWN WITH USDA WHITE MINERAL OIL OR VEGETABLE OIL AS A RUST INHIBITOR

REV	BY	DATE	DESCRIPTION
D	BP	9/8/22	ADDED NOTE TO DRAWING TO APPLY MINERAL OR VEGETABLE OIL
C	WEB	12/7/15	ADDED NOTES, UPDATED TITLEBLOCK
B	WEB	1/23/14	THREAD CALL OUT WAS 4-4 UNC - 2A
A	CHL	6/24/10	NEW PART ADDED TO SYSTEM

UNLESS OTHERWISE SPECIFIED DIMENSIONAL TOLERANCES FRACTIONAL: $\pm 1/16$ X.XX: $\pm .03$ X.XXX: $\pm .015$ ANGULAR: $\pm 1^\circ$ DEBURR ALL SHARP EDGES. ALL MACHINED SURFACES TO HAVE A 125 RMS FINISH UNLESS NOTED OTHERWISE. THIRD ANGLE PROJECTION	DRAWN BY:	CHL
	CHECKED BY:	VD
	PROTOTYPE DATE:	2/2/2010
	APPROVED FOR PRODUCTION BY:	VD
	PRODUCTION DATE:	6/24/2010
	SIZE:	D
DRAWING #:	28092	

SALCO PRODUCTS, INC.		
PART NAME: QUICK CONNECT ADAPTER 4" FLANGED		
MATERIAL: SEE BOM		
PROJECT #:	WAG0768	SHEET #: 1 OF 1
PART #:		SCALE: 1:1
TE4IUTF7		