

NO.	PART NAME	PART #	REQ'D	MATERIAL
1	QUICK CONNECT ADAPTER 4" FLANGED	K4ITF	1	DUCTILE IRON
2	FLANGE GASKET 4"	K4TFG	1	WHITE NITRILE

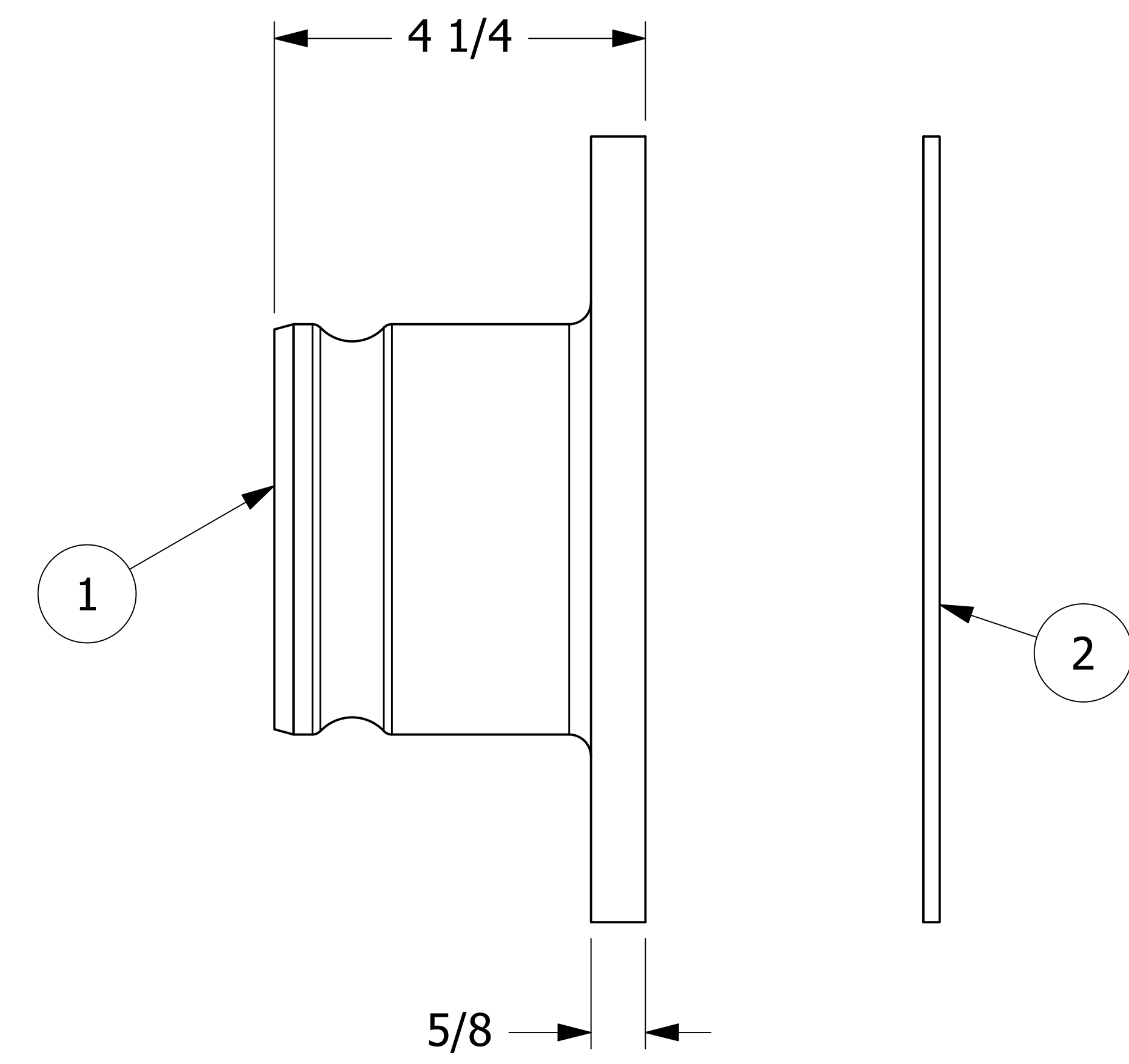
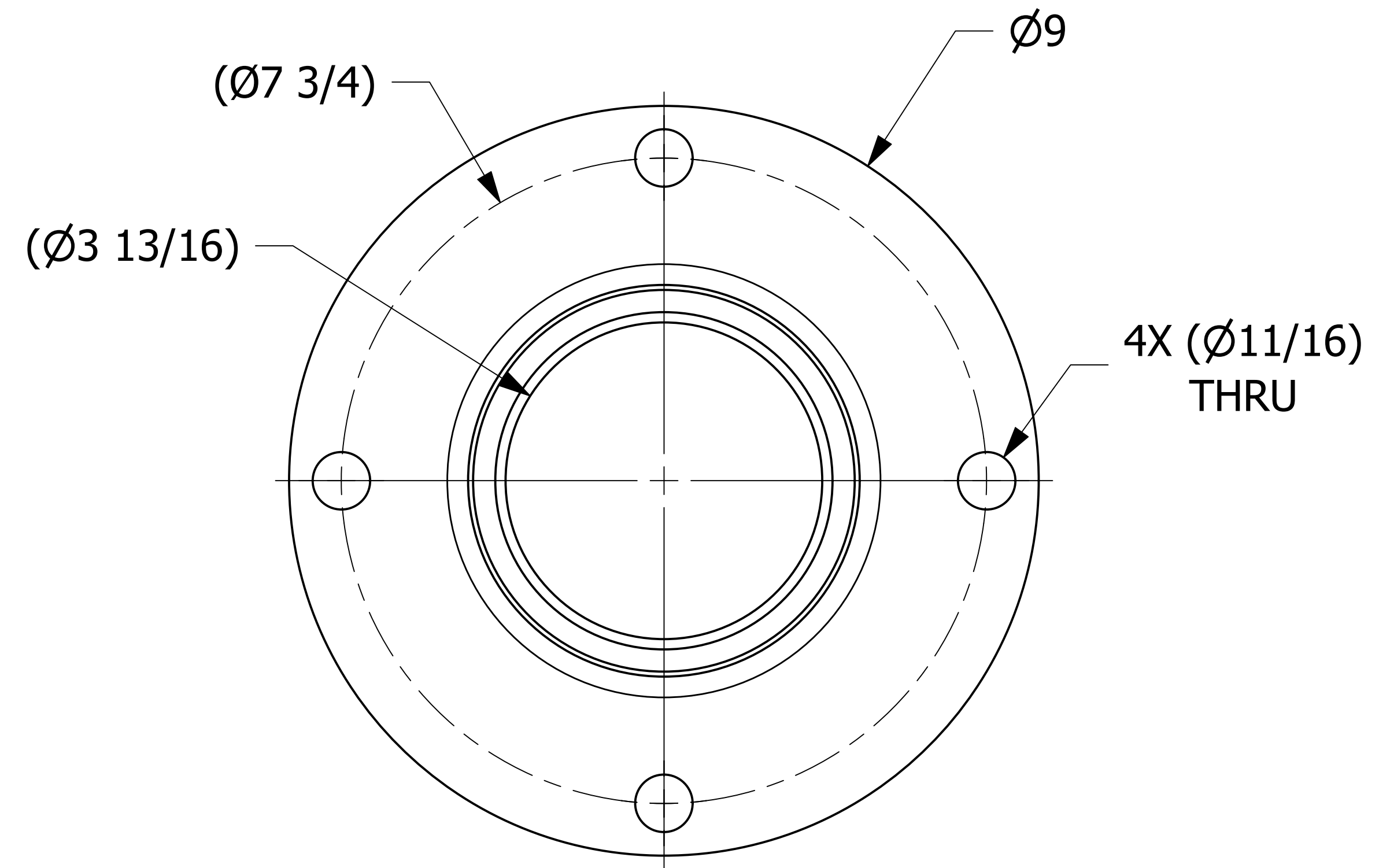

NOTES:

1. THIS ASSEMBLY IS NOT DOT APPROVED AND CAN BE USED ONLY ON AAR STENCILED CARS.
2. QUICK DISCONNECT MEETS MIL-C-27487G SPECS.
3. FLANGE IS DUCTILE IRON (FERRITIZED/ANNEALED) AND MEETS ASTM A395 GRADE 60-40-18 REQUIREMENTS.
4. SPRAY WITH USDA APPROVED WHITE MINERAL OIL OR VEGETABLE OIL AS A RUST INHIBITOR.
5. FITS TRINITY/UNION TANK 4" BALL VALVE (7.75" B.C.)
6. AAR APPROVAL # E-232133.

D	RPS	4/4/24	AAR APPROVAL # WAS E-139514.
C	BP	11/29/22	EDITED SCALE AND ANNOTATIONS: UPDATED THE TITLEBLOCK : UPDATED THE AAR APPROVAL NUMBER FROM E-019022 TO E-139514
B	TAJ	6/29/11	AAR APPROVAL # WAS E-039015
A	CHL	1/5/04	AAR APPROVAL# WAS E-939034
REV	BY	DATE	DESCRIPTION

UNLESS OTHERWISE SPECIFIED DIMENSIONAL TOLERANCES FRACTIONAL: $\pm 1/16$ X.XX: $\pm .03$ X.XXX: $\pm .015$ ANGULAR: $\pm 1^\circ$ DEBURR ALL SHARP EDGES. ALL MACHINED SURFACES TO HAVE A 125 RMS FINISH UNLESS NOTED OTHERWISE. THIRD ANGLE PROJECTION	DRAWN BY:	FOD
	CHECKED BY:	ACC
	PROTOTYPE DATE:	3/6/2000
	APPROVED FOR PRODUCTION BY:	ACC
	PRODUCTION DATE:	3/6/2000
	SIZE:	D
DRAWING #:	14135	

SALCO PRODUCTS, INC.

QUICK CONNECT ADAPTER 4" FLANGED

MATERIAL: **SEE BOM**

PROJECT #: _____ SHEET #: **1 OF 1** SCALE: **3:4**

PART #: **K4ITF2**