

NO.	PART NAME	PART#	REQ'D	MATERIAL
1	HEX BOLT 3/8-16 X 1 3/4"	EA111B	1	CS Z/P
2	HEX LOCK NUT 3/8"-16	EA111N	1	CS Z/P
3	QUICK CONNECT ADAPTER 4" THREAD ON	K4IA	1	DUCTILE IRON
4	FLAT WASHER 3/8" USS	KL103FW	2	CS Z/P
5	S-HOOK 3/8"X3 1/2"	SC38SH	1	CS Z/P
6	CHAIN LINKS 3/8"X15	SC4315C	1	AISI 1008 CS
7	ADAPTER GASKET 5 1/4" RR	SSA4GV	1	BLACK VITON A

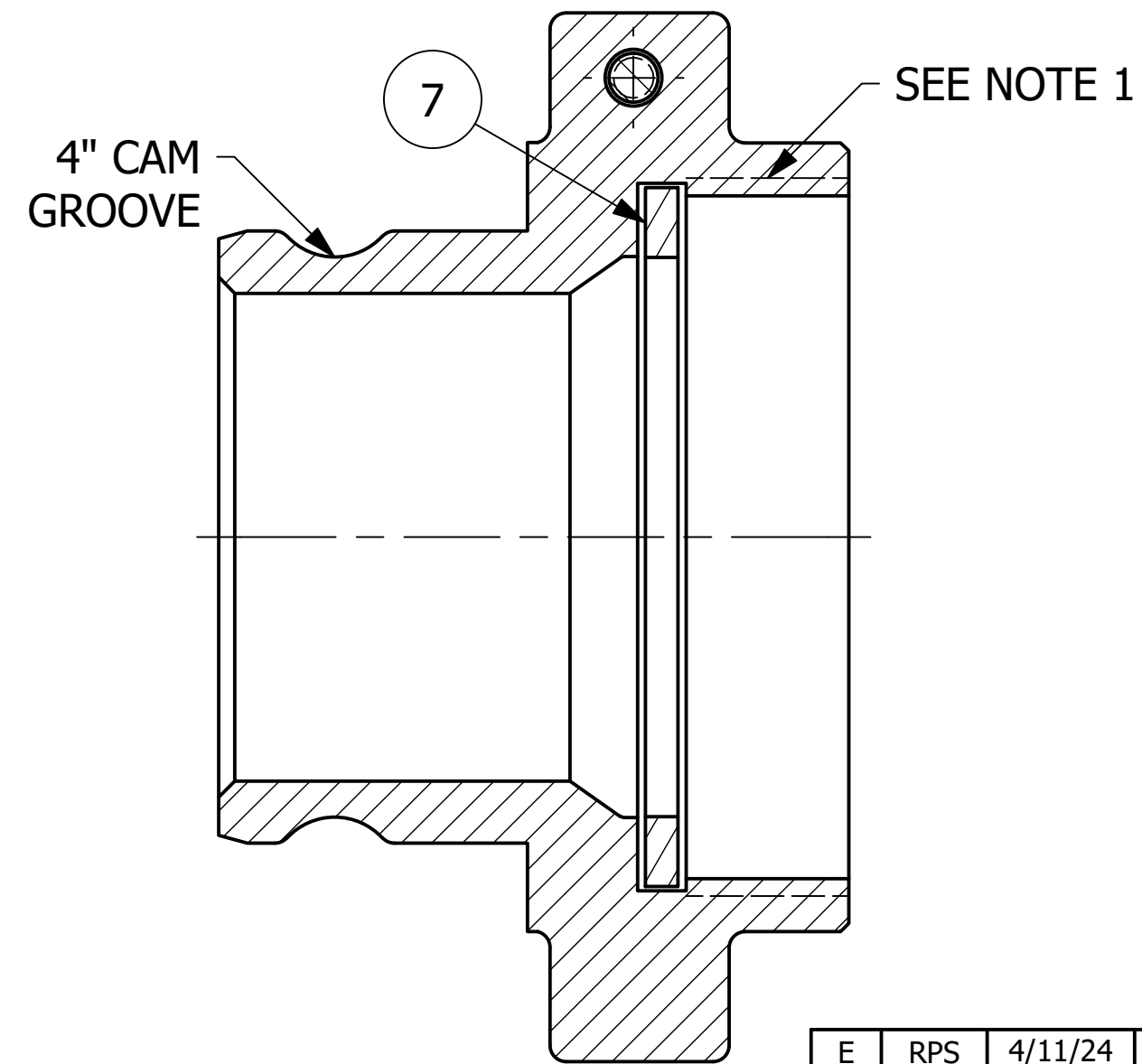
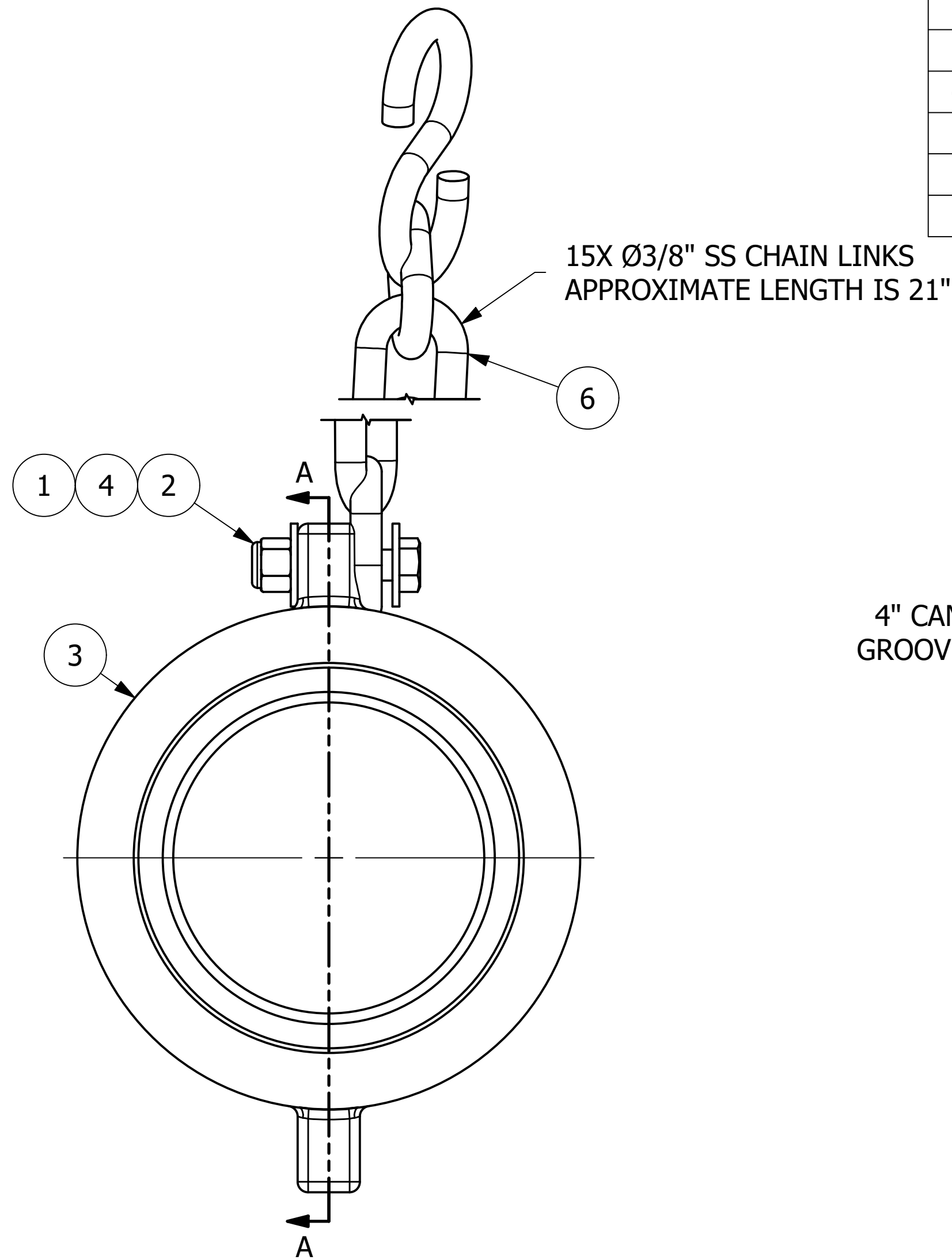

SECTION A-A

NOTES:

- 5-1/4" - 4 UN 2B THREADS CONFORM TO ANSI B1.1 STANDARD AND FIGURE E18 FROM AAR TANK CAR MANUAL.
- THIS ASSEMBLY IS NOT DOT APPROVED AND CAN BE USED ONLY ON AAR STENCILED CARS.
- QUICK DISCONNECT MEETS A-A-59326D.
- ADAPTER IS DUCTILE IRON (FERRITIZED/ANNEALED) AND MEETS ASTM A395 GRADE 60-40-18 REQUIREMENTS.
- SPRAY WITH USDA APPROVED WHITE MINERAL OIL OR VEGETABLE OIL AS A RUST INHIBITOR.
- AAR APPROVAL # E-232133.

REV	BY	DATE	DESCRIPTION
E	RPS	4/11/24	AAR APPROVAL # WAS E-139514.
D	WEB	5/5/22	REPLACED 16X SC43 W/ SC4315C; UPDATED TITLE BLOCK
C	RJP	10/29/13	AAR APPROVAL # WAS E-019022 MIL SPEC WAS MIL-C-27487G
B	TAJ	6/24/11	AAR APPROVAL # WAS E-039015
A	ACC	1/28/05	ADDED PART INTO SYSTEM

UNLESS OTHERWISE SPECIFIED DIMENSIONAL TOLERANCES FRACTIONAL: ±1/16 X.XX: ±.03 X.XXX: ±.015 ANGLE: ±1° DEBURR ALL SHARP EDGES. ALL MACHINED SURFACES TO HAVE A 125 RMS FINISH UNLESS NOTED OTHERWISE THIRD ANGLE PROJECTION	DRAWN BY: CHL CHECKED BY: ACC PROTOTYPE DATE: 1/28/2005 APPROVED FOR PRODUCTION BY: ACC PRODUCTION DATE: 1/28/2005 SIZE: C DRAWING #: 19008
---	---

SALCO PRODUCTS, INC.

PART NAME: **QUICK CONNECT ADAPTER 4" THREAD ON**

MATERIAL: **SEE BOM**

PROJECT #: **WAG0116** SHEET #: **1 OF 1** SCALE: **3:4**

PART #: **K4IA6A**