

SALES DRAWING SALES DRAWING SALES DRAWING SALES DRAWING SALES DRAWING

SALES DRAWING SALES DRAWING SALES DRAWING SALES DRAWING SALES DRAWING

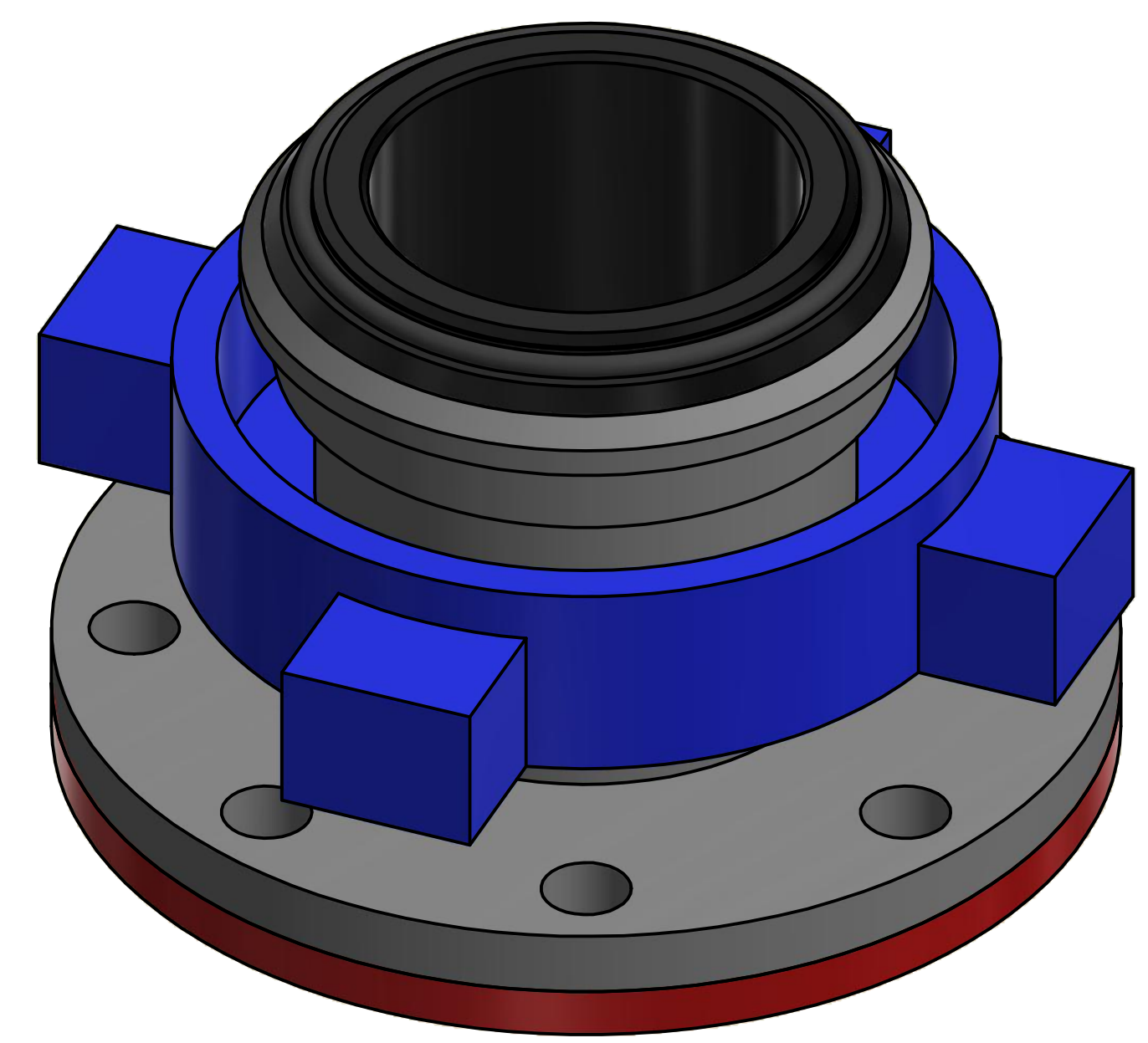
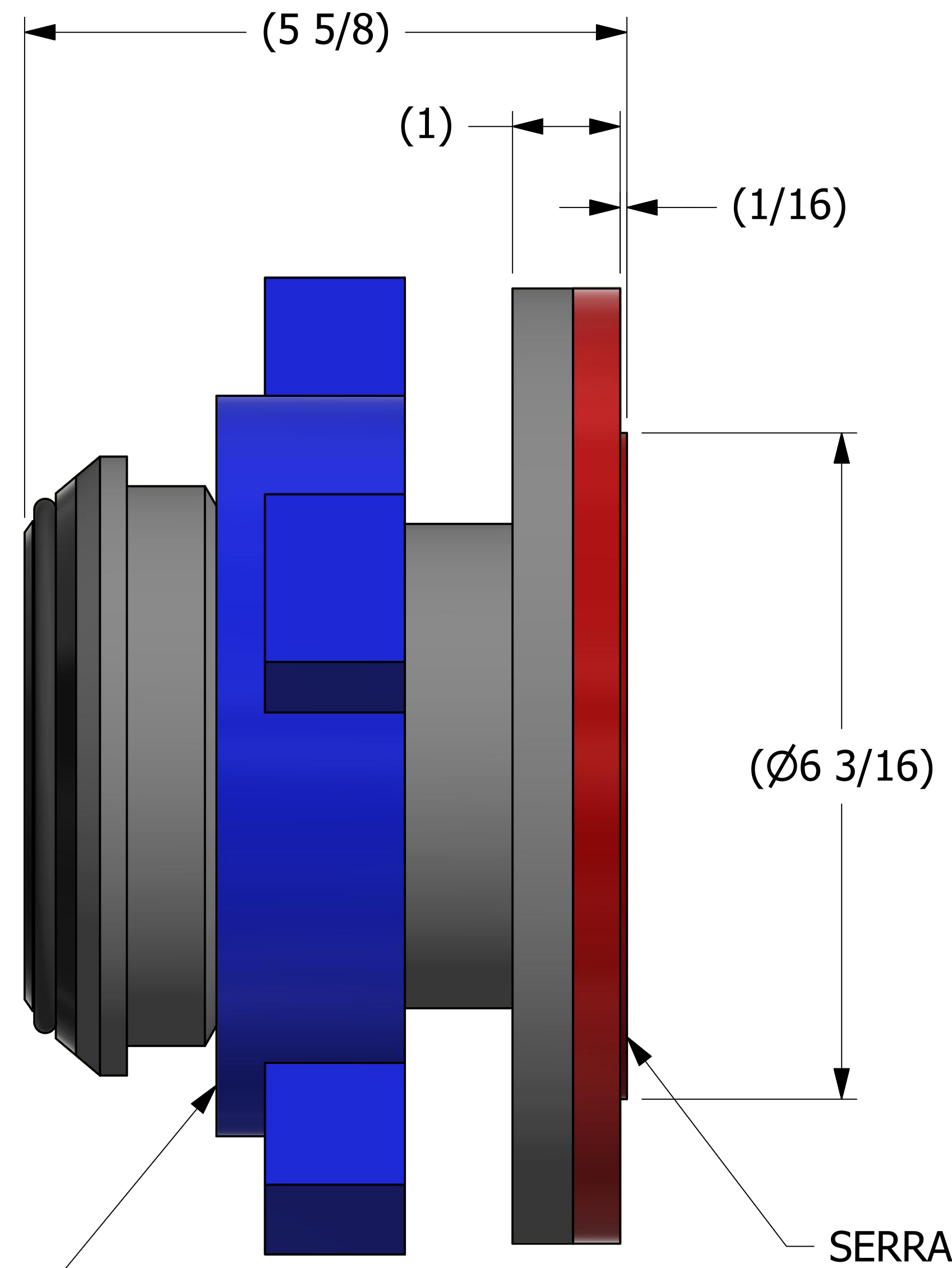
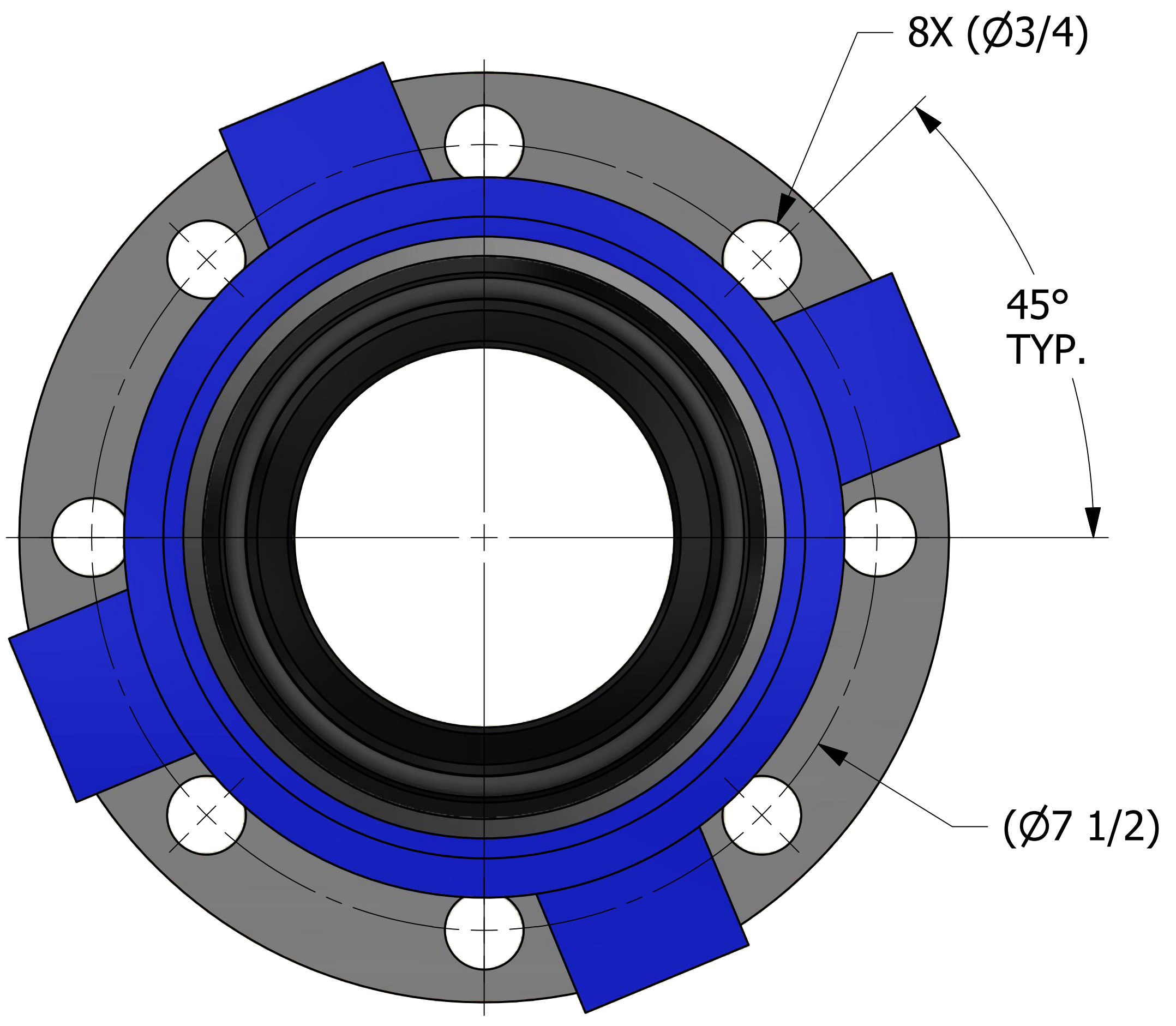

6.125"-3
FEMALE ACME THREAD

SERRATED GASKET
SURFACE

- NOTES:
1. APPROXIMATE WEIGHT IS 18 LBS.
2. HAMMER UNION IS UNPAINTED.

UNLESS OTHERWISE SPECIFIED
DIMENSIONAL TOLERANCES
FRACTIONAL: ±1/16
X.XX: ±.03
X.XXX: ±.015
ANGULAR: ±1°
DEBURR ALL SHARP EDGES.
ALL MACHINED SURFACES TO
HAVE A 125 RMS FINISH
UNLESS NOTED OTHERWISE.
THIRD ANGLE PROJECTION

DRAWN BY: EJF
CHECKED BY:
PROTOTYPE DATE: 2/28/2019
APPROVED FOR PRODUCTION BY: MJW
PRODUCTION DATE: 10/15/2019
SIZE: D
DRAWING #: 48668

B	WEB	11/6/19	201911061255	WEB
REV	BY	DATE	REF #	PUB
SALCO PRODUCTS, INC.				
PART NAME: LINED HAMMER UNION MALE 4" FLANGED				
MATERIAL: DUCTILE IRON/BUNA/STEEL/SALCO PE				
PROJECT #: H161028T			SHEET #: 1 OF 1	SCALE: 1 : 1
PART #: HSHU4FXM206				