

SALES DRAWING

SALES DRAWING

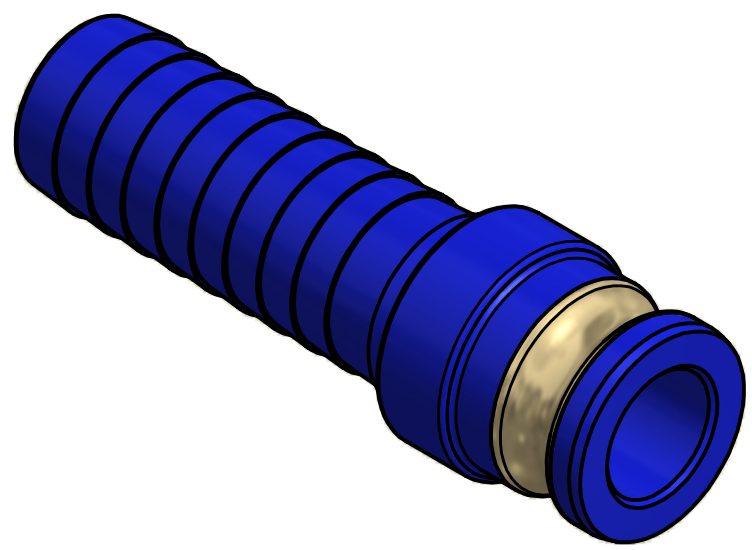
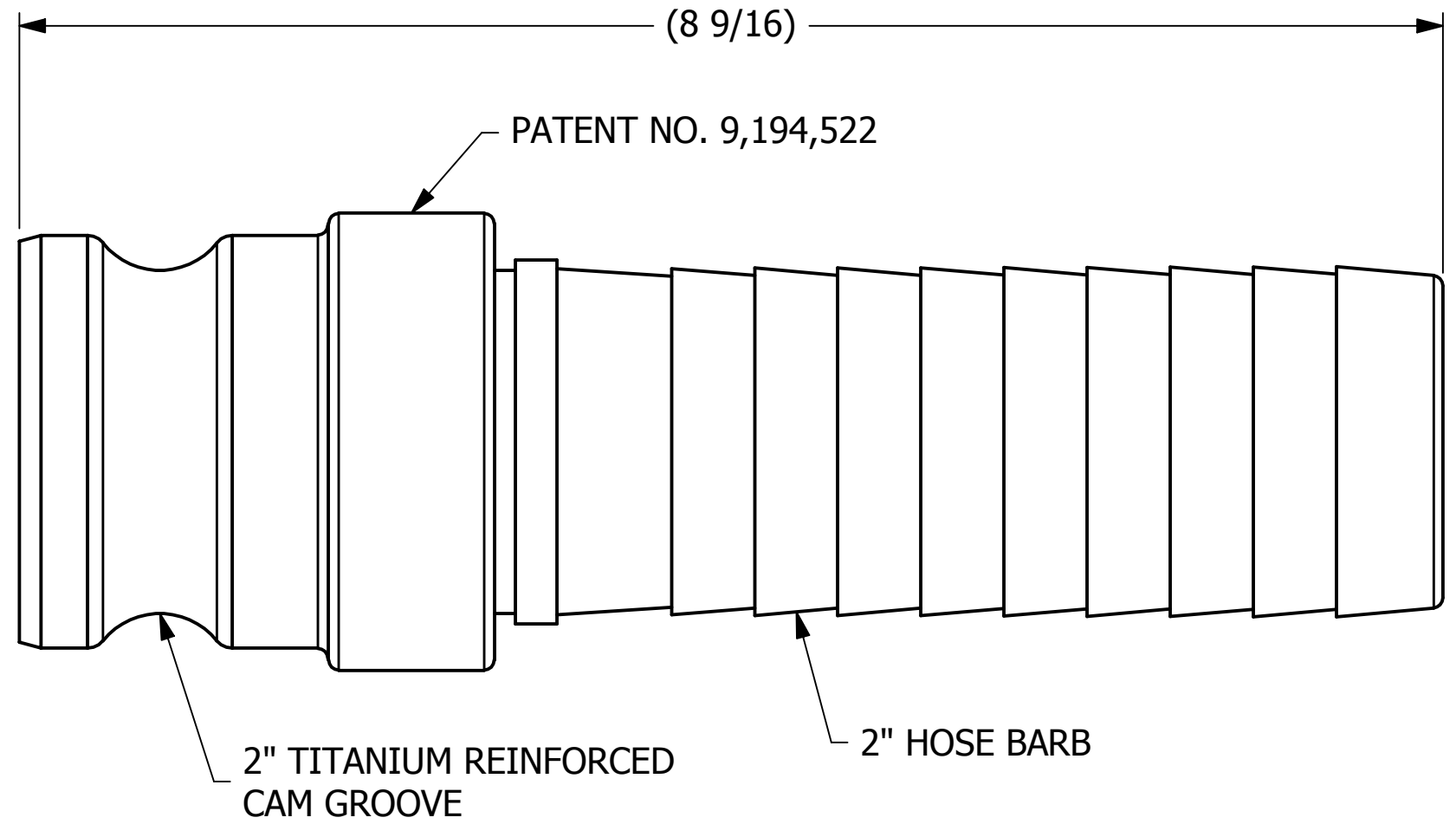
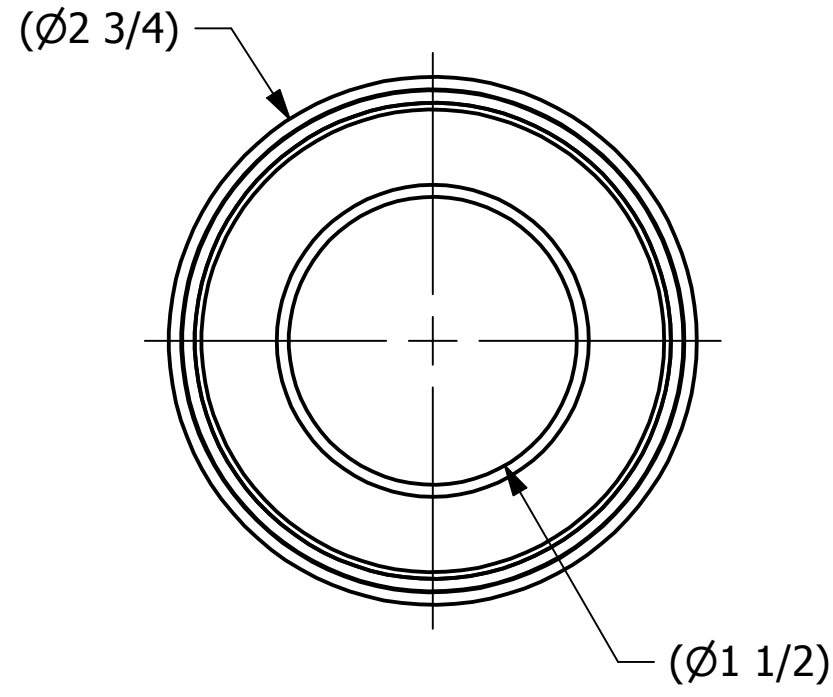

ISOMETRIC VIEW

NOTE:
PROFILE MEETS A-A-59326D.

REV	BY	DATE	DESCRIPTION
D	TAK	2-1-16	UPDATED PATENT NUMBER & DESCRIPTION
C	WEB	11-7-14	ADDED VICTAULIC GROOVE
B	WEB	6-6-14	ADDED NOTE 1, UPDATED DIMS
A	WEB	3-21-13	RELEASED FOR PRODUCTION

UNLESS OTHERWISE SPECIFIED DIMENSIONAL TOLERANCES		DRAWN BY:	KHK
FRACTIONAL:	±1/16	CHECKED BY:	WRB
X.XX:	±.03	PROTOTYPE BY:	KHK
X.XXX:	±.015	PROTOTYPE DATE:	12/12/2012
ANGULAR:	±1°	APPROVED FOR PRODUCTION BY:	WRB
DEBURR ALL SHARP EDGES. ALL MACHINED SURFACES TO HAVE A 125 RMS FINISH UNLESS NOTED OTHERWISE.		PRODUCTION DATE:	3/21/2013
THIRD ANGLE PROJECTION			

PART NAME: HOSE BARB CAMMED 2"		
MATERIAL: SALCO PE/TITANIUM		
PROJECT #:	121211	SHEET #:
		1 OF 1
DRAWING #:		SCALE:
B34816		1:1
PART #:		
HS2KREP01		

THIS PRINT, PROPERTY OF SALCO PRODUCTS INC., CONTAINS PROPRIETARY INFORMATION AND MUST NOT BE COPIED, REPRODUCED, OR USED DETRIMENTALLY TO OUR INTEREST.