

NO.	PART NAME	PART#	REQ'D	MATERIAL
1	ANGLE BRACKET	A30299	2	304/316 SS
2	EYEBOLT 3/8"-16X1 1/2"	A30300	2	18-8 SS
3	BUSHING	A45653	2	CS Z/P
4	ROUND TUBE 1"X4 7/8"	A46363	1	12 GA. ASTM A513 TYPE 5 OR TYPE 6
5	DUAL TORSION SPRING	C46364	1	302 SS
6	HEX BOLT 3/4"-10 X 8 1/2"	HB13380	1	CS Z/P
7	TOP LOCK NUT 3/4"-10	LN37274	1	CS Z/P
8	NUT LOCK HEX 3/8-16	LN70862	2	18-8 SS
9	FLAT WASHER 3/4" SAE	WASH34SAE	2	CS Z/P

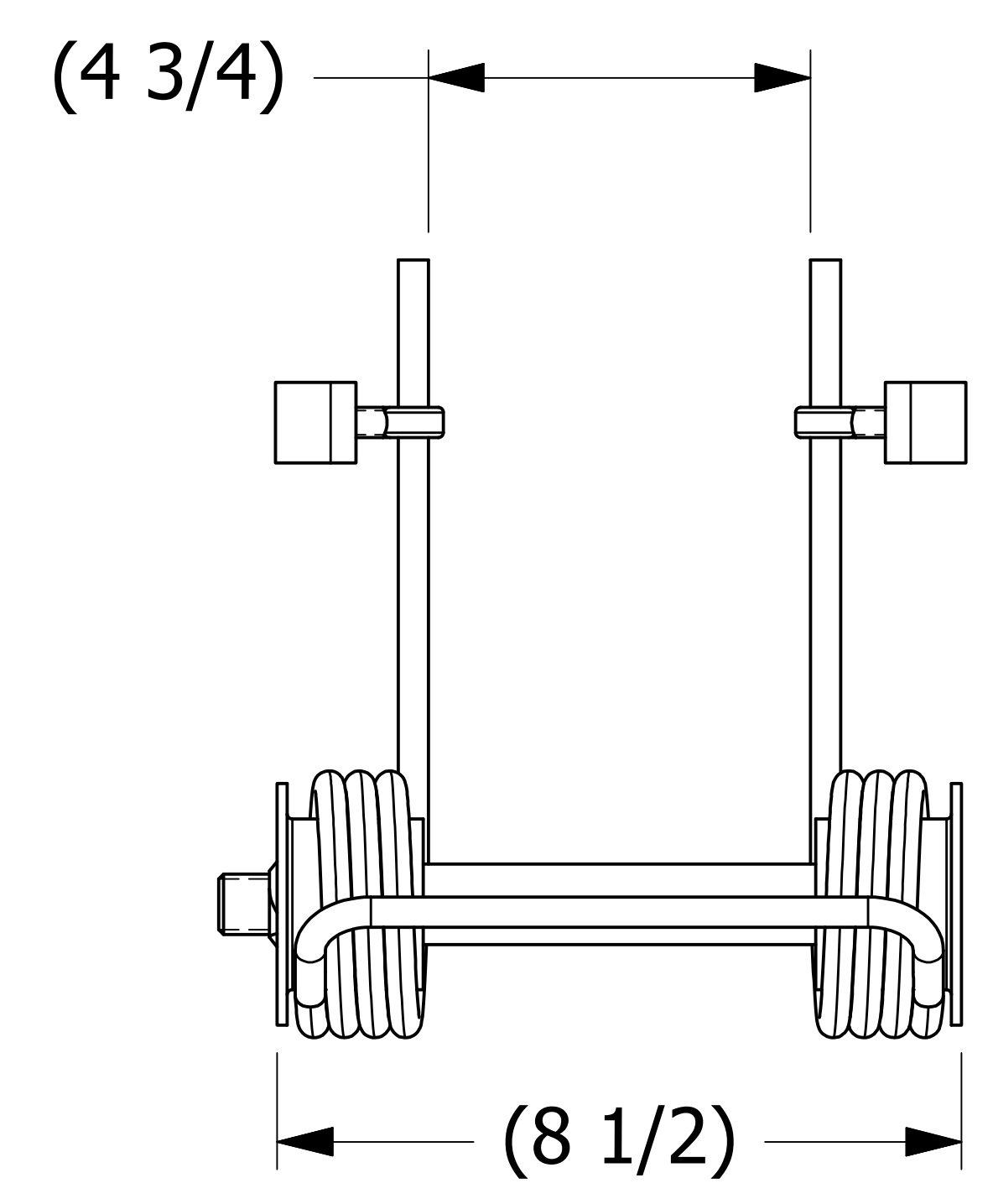

FRONT VIEW  
SCALE 1 : 2

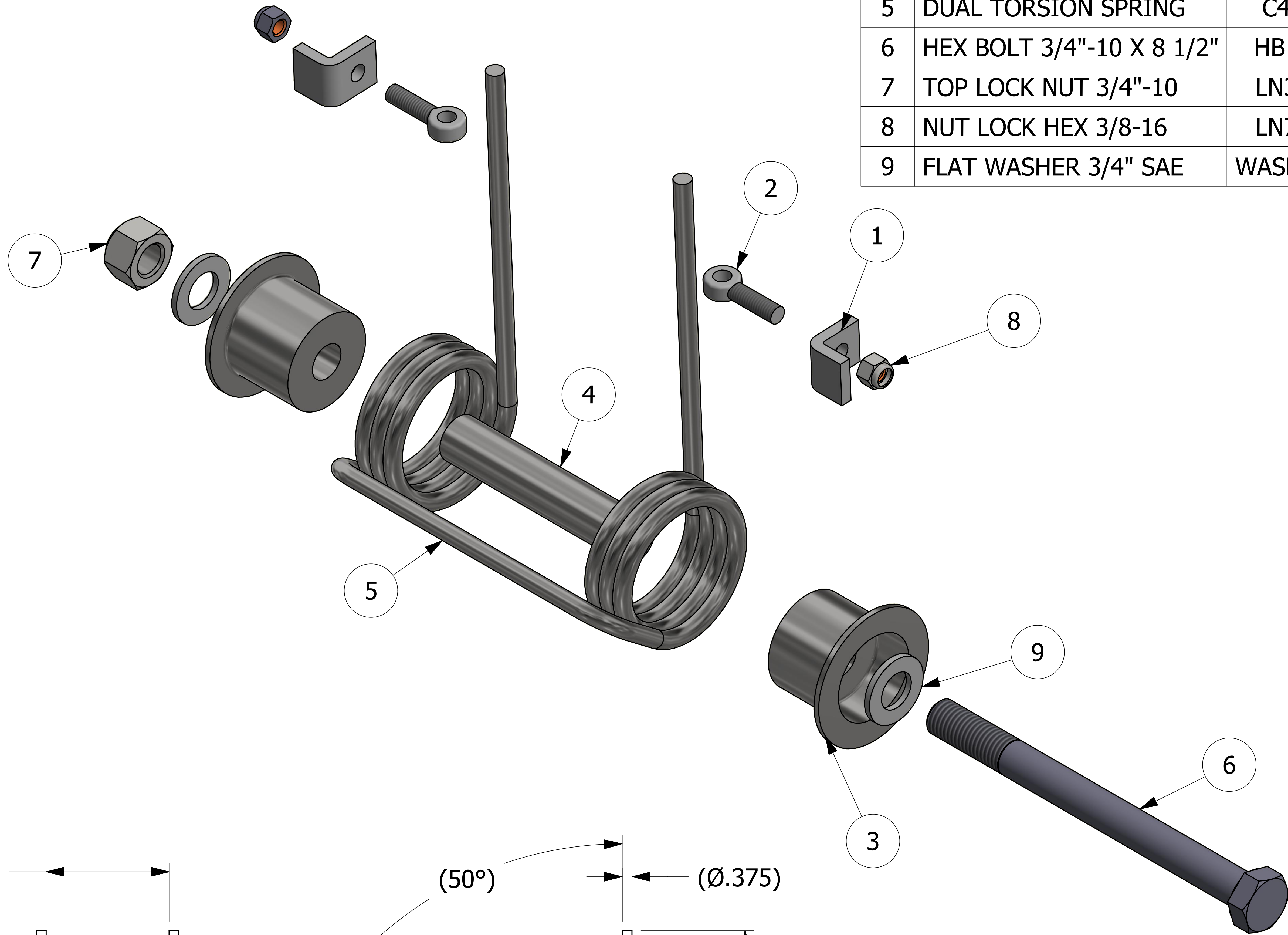
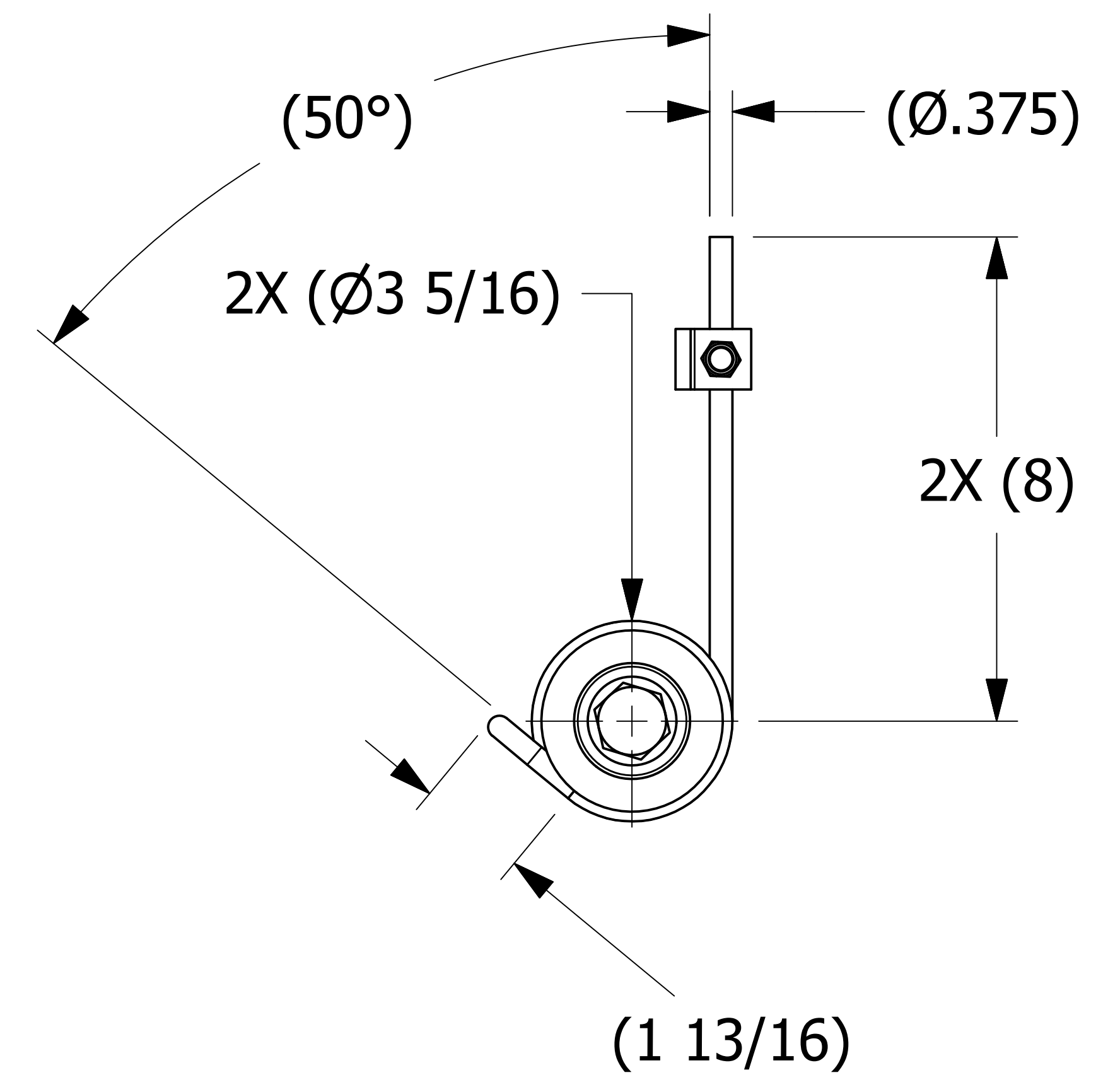

NOTES:  
 1. FITS ON SALCO 20" STYLE MANWAY COVER.  
 2. APPROX. TORQUE @ 70° DEFLECTION: 150 FT-LBS.

B	WEB	10/28/20	REPLACED LN77798 W/ LN70862; UPDATED TITLE BLOCK; SORTED BOM
A	JG	1/11/18	RELEASED FOR PRODUCTION
REV	BY	DATE	DESCRIPTION

UNLESS OTHERWISE SPECIFIED DIMENSIONAL TOLERANCES FRACTIONAL: ±1/16 X.XX: ±.03 X.XXX: ±.015 ANGULAR: ±1° DEBURR ALL SHARP EDGES. ALL MACHINED SURFACES TO HAVE A 125 RMS FINISH UNLESS NOTED OTHERWISE. THIRD ANGLE PROJECTION	DRAWN BY:	JG
	CHECKED BY:	VD
	PROTOTYPE DATE:	12/11/2017
	APPROVED FOR PRODUCTION BY:	VD
	PRODUCTION DATE:	1/11/2018
	SIZE:	E
DRAWING #:	46365	

**SALCO PRODUCTS, INC.**

**LIFT ASSIST - UTC STANDARD**

MATERIAL: **SEE BOM**

PROJECT #: **110228B** SHEET #: **1 OF 1** SCALE: **1 : 1**

PART #: **LAD20UT5**