

NO.	PART NAME	PART#	REQ'D	MATERIAL
1	BAR 5/16" X 5 1/2"	A17220	1	CS
2	EYEBOLT ASSEMBLY 3/4"X6 1/2"	EB3465A	1	CS
3	HEAVY HEX NUT 3/4"-10	N34X	1	CS
4	FLAT WASHER 3/4" USS	WASH34	1	CS

APPLY A BEAD OF WELD TO THE 2 END THREADS  
AFTER INSTALLING WASHER AND NUT

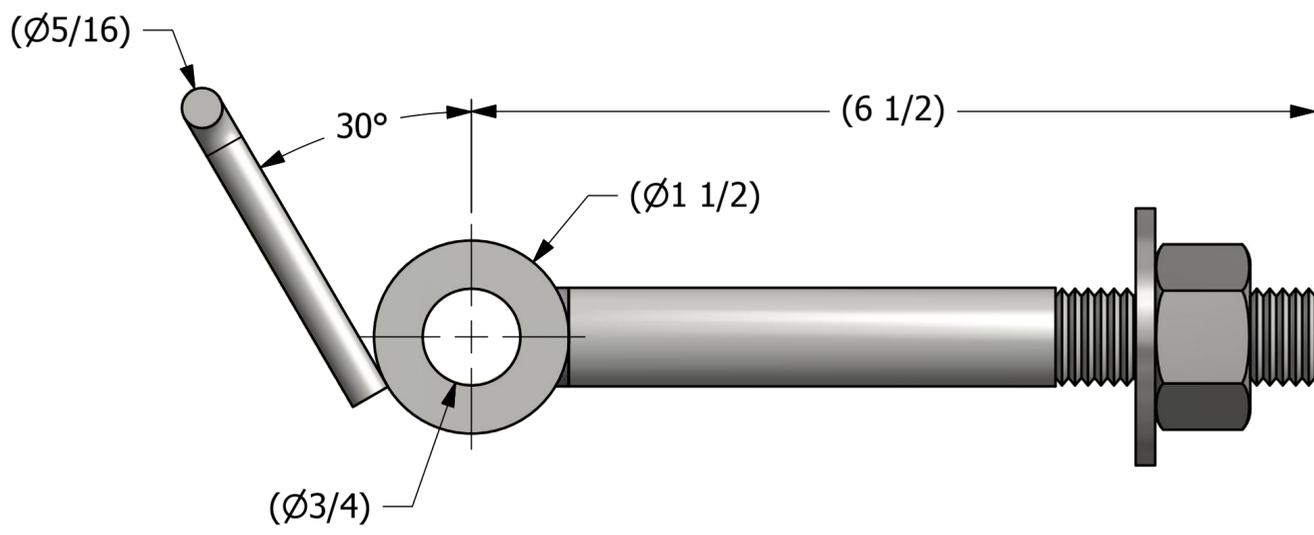
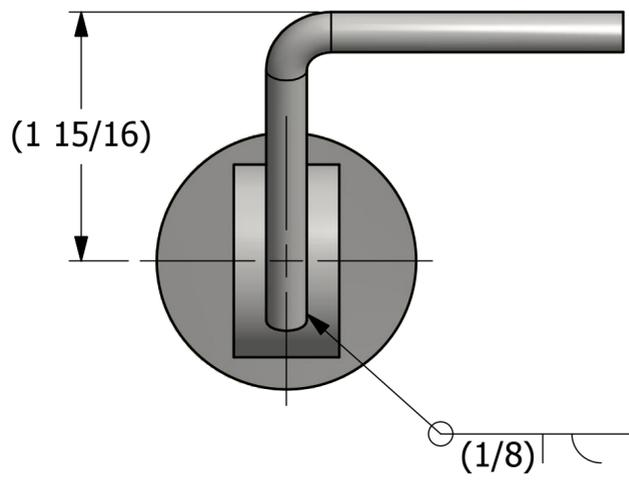
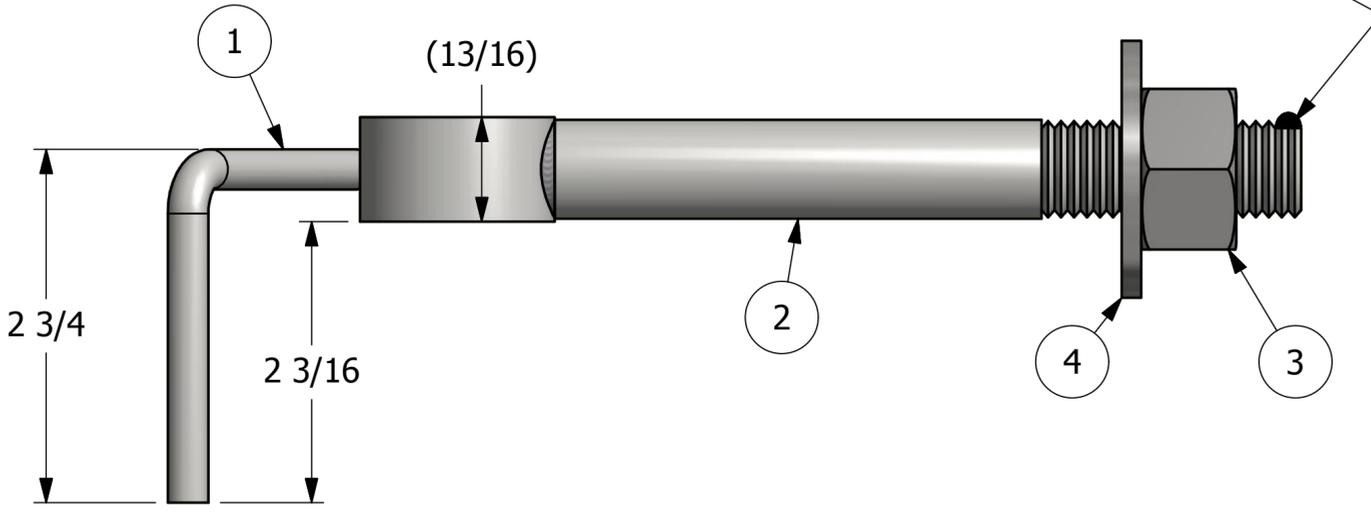

NOTE:  
SEE DOCUMENT DSS 12 FOR WELDING SPECIFICATIONS.

REV	BY	DATE	DESCRIPTION
A	JG	12-19-17	UPDATED TITLE BLOCK; ADDED WELD NOTE; WELD SIZE WAS 1/4"

<small>UNLESS OTHERWISE SPECIFIED DIMENSIONAL TOLERANCES FRACTIONAL: ±1/16 X.XX: ±.03 X.XXX: ±.015 ANGLE: ±1° DEBURR ALL SHARP EDGES. ALL MACHINED SURFACES TO HAVE A 125 RMS FINISH UNLESS NOTED OTHERWISE.</small>	DRAWN BY:	CHL
	CHECKED BY:	ACC
	PROTOTYPE BY:	CHL
	PROTOTYPE DATE:	8/20/2002
	APPROVED FOR PRODUCTION BY:	ACC
	PRODUCTION DATE:	9/25/2002

**SALCO PRODUCTS, INC.**

PART NAME: **EYEBOLT LOCK ASSEMBLY 3/4"X6 1/2"**

MATERIAL: **SEE BOM**

PROJECT #: \_\_\_\_\_ SHEET #: **1 OF 1** SCALE: **1:1**

DRAWING #: **C17217** PART #: **EBL3465XA**