

NO.	PART NAME	PART#	REQ'D	MATERIAL
1	LOADING SPOUT ASSEMBLY	HSCSL1813A01	1	PP/EPDM
2	FLANGE GASKET 3" 150 LB	FG2315029	5	BLACK EPDM
3	PIPE SPOOL 3"X2"	HSSP3X2P	1	SALCO PE
4	BUTTERFLY VALVE 3"	AS3722-030	2	PVC/PVC/EPDM
5	FLANGE GASKET 2" 150 LB	FG2215029	3	BLACK EPDM
6	PARALLEL INSTRUMENT TEE 2"X2"	HSPIT2X2	1	SALCO PE
7	QUICK CONNECT FLANGE 2"	HS2FTKRPY	2	SALCO PE/SS
8	STUD 5/8"-11X7" FULL THREAD	STUD587SS	8	18-8 SS
9	FLAT WASHER 5/8"	WASH58SS	8	18-8 SS
10	HEX NUT 5/8"-11	NUT58SS	40	18-8 SS
11	STUD 5/8"-11X5 1/2"	STUD58512SS	4	18-8 SS
12	STUD 5/8"-11X8" FULL THREAD	STUD588SS	4	304 SS
13	STUD 5/8"-11X6 1/2" FULL THREAD	STUD58612SS	4	304 SS
14	SEGMENTED WASHER 6"	WS60S03	8	304 SS
15	SEGMENTED WASHER 4 3/4"	WS475S09	8	316 SS
16	PIPE SPOOL 3"	HSSP37210	1	SALCO PE
17	QUICK CONNECT FLANGE 3"	HS3FTKRPY	1	SALCO PE/SS

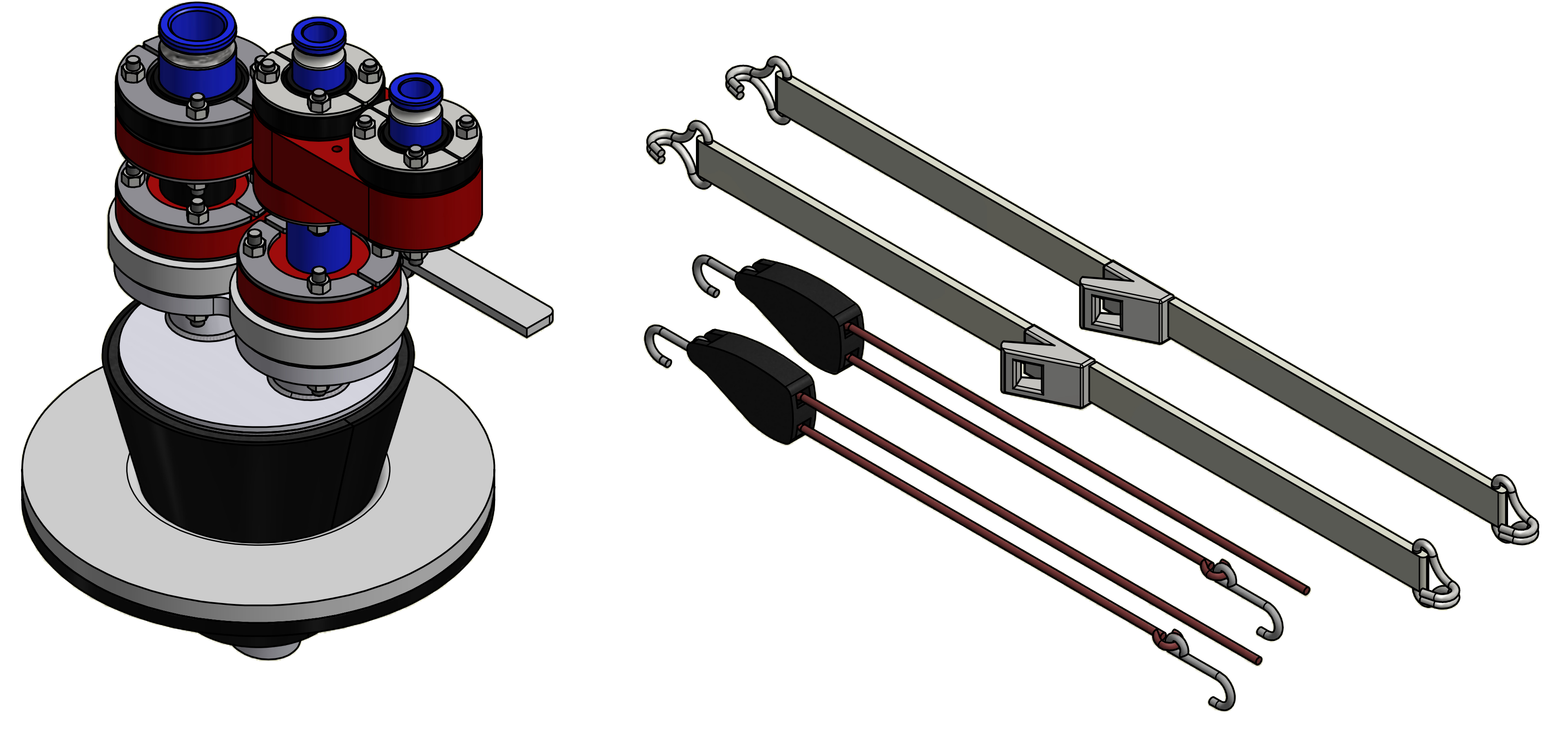

A	KHK	9-16-13	RELEASED FOR PRODUCTION
REV	BY	DATE	DESCRIPTION

UNLESS OTHERWISE SPECIFIED DIMENSIONAL TOLERANCES FRACTIONAL: ±1/16 X.XX: ±.03 X.XXX: ±.015 ANGULAR: ±1° DEBURR ALL SHARP EDGES. ALL MACHINED SURFACES TO HAVE A 125 RMS FINISH UNLESS NOTED OTHERWISE. THIRD ANGLE PROJECTION	DRAWN BY:	KHK
	CHECKED BY:	CHL
	PROTOTYPE BY:	KHK
	PROTOTYPE DATE:	8/9/2013
	APPROVED FOR PRODUCTION BY:	VD
	PRODUCTION DATE:	9/16/2013

SALCO PRODUCTS, INC.

PART NAME:
LOADING SPOUT ASSEMBLY

MATERIAL:
SEE BOM

PROJECT #:	130805	SHEET #:	1 OF 1	SCALE:	2:3
DRAWING #:	E36928	PART #:	HSCSL1813A05		