

NO.	PART NAME	PART#	REQ'D	MATERIAL
1	BALL VALVE 1"	AS5801010	1	POLYETHYLENE
2	WELD INSERT 1"	A29162	1	SALCO PE
3	FLANGE BLANK 1"	HS438FL	1	SALCO PE
4	HOSE BARB INSERT 1"	A29160	1	SALCO PE
5	AIR HOSE 1"	H1-T330AH100	2 FT	EPDM
6	CHICAGO COUPLING 1"	RAM-11	1	316 SS
7	HOSE CLAMP 13/16"-1 1/2"	HCWD15S6	4	316 SS

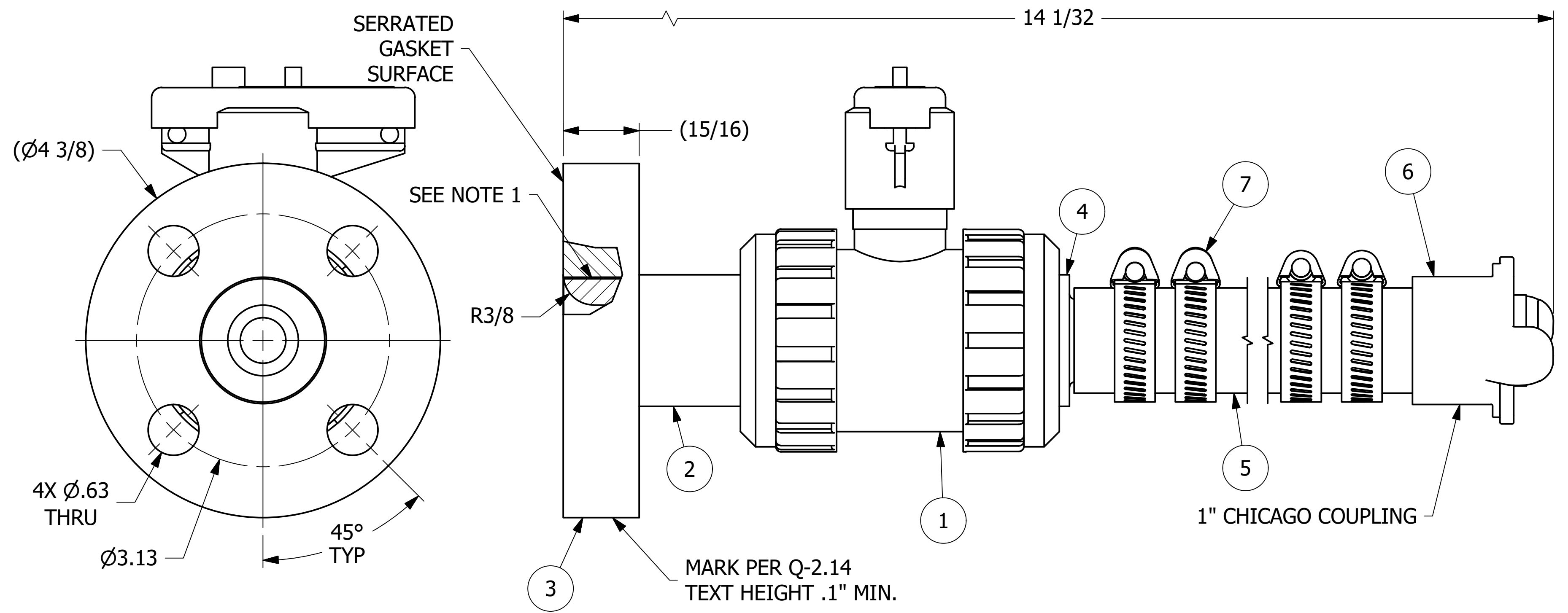

- NOTES:
1. SEE DOCUMENT DSS 3 FOR FRICTION WELDING SPECIFICATIONS.
 2. SEE DOCUMENT Q-2.14 FOR MARKING PROCEDURES.
 3. TEST PER Q-2.15.7.

UNLESS OTHERWISE SPECIFIED
 DIMENSIONAL TOLERANCES
 FRACTIONAL: ±1/16
 X.XX: ±.03
 X.XXX: ±.015
 ANGLE: ±1°
 DEBURR ALL SHARP EDGES.
 ALL MACHINED SURFACES TO
 HAVE A 125 RMS FINISH UNLESS
 NOTED OTHERWISE.

DRAWN BY: WRB
 CHECKED BY: EJF
 PROTOTYPE BY: WRB
 PROTOTYPE DATE: 8/4/2010
 APPROVED FOR PRODUCTION BY: MJW
 PRODUCTION DATE: 6/24/2019

REV	CHL	DATE	DESCRIPTION
A	CHL	6-24-19	RELEASED FOR PRODUCTION

SALCO PRODUCTS, INC.
 PART NAME: AIR VALVE ASSEMBLY 1"
 MATERIAL: SEE BOM
 PROJECT #: 100725 SHEET #: 1 OF 1 SCALE: 1:1
 DRAWING #: C29218 PART #: HSAVA29218