

NO.	PART NAME	PART #	REQ'D	MATERIAL
1	INSERT FLANGE 6" 150 LB	HS6FLS4	1	304 SS
2	HOSE BARB 6"	HS6HBP	1	SALCO PE

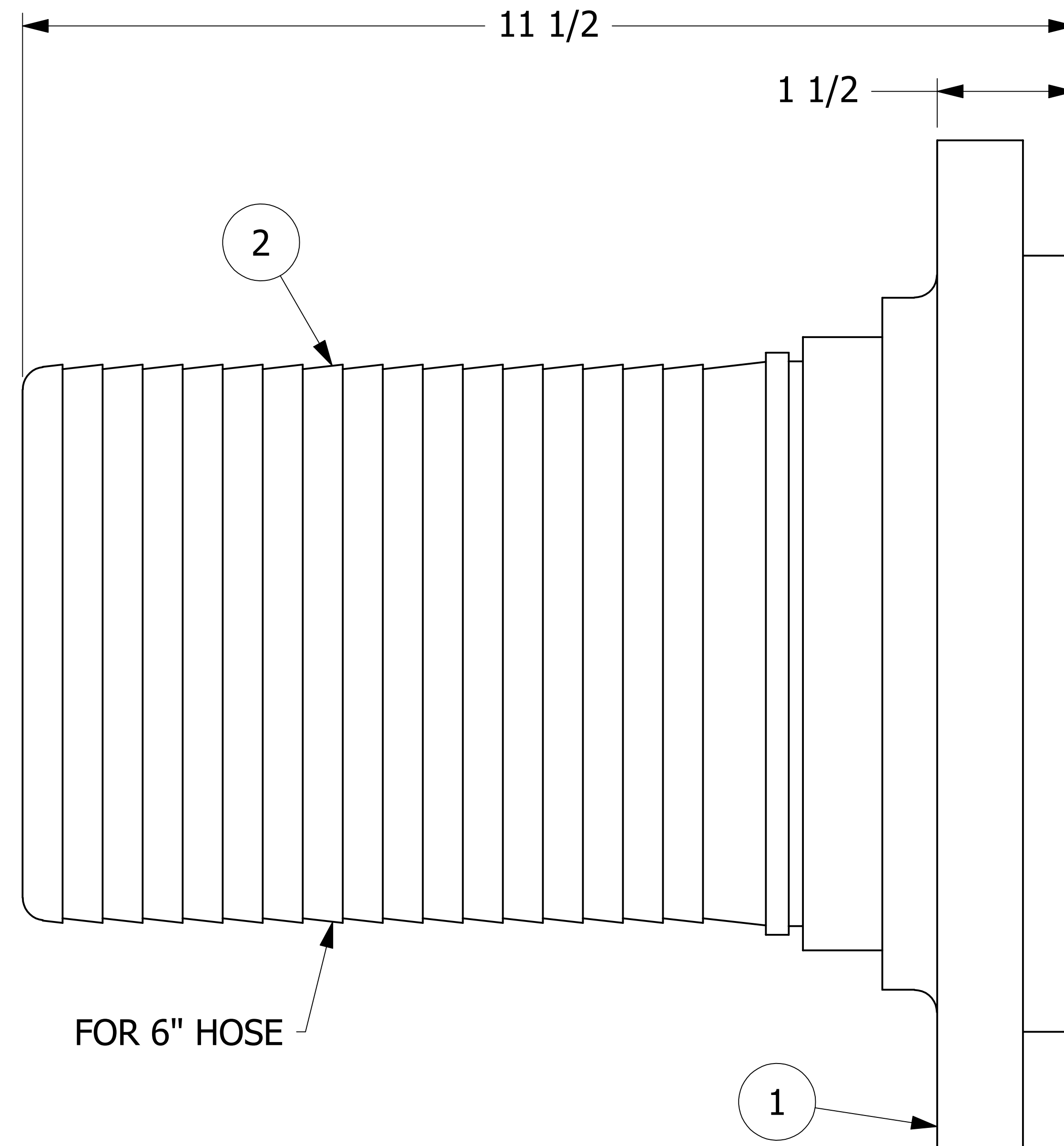
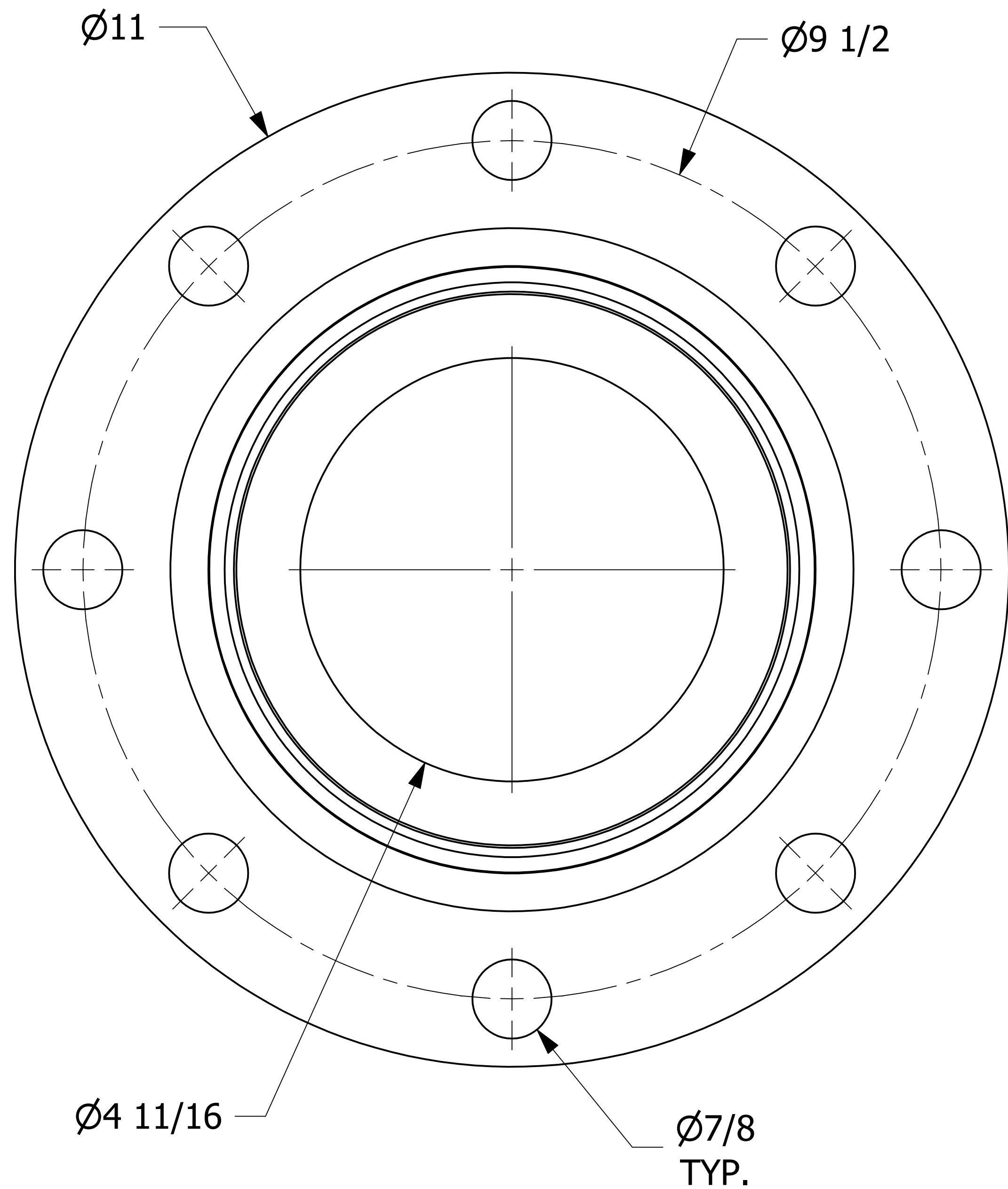

A	CHL	10-18-12	DRAWING ADDED TO NETWORK
REV	BY	DATE	DESCRIPTION

UNLESS OTHERWISE SPECIFIED DIMENSIONAL TOLERANCES FRACTIONAL: ±1/16 X.XX: ±.03 X.XXX: ±.015 ANGULAR: ±1° DEBURR ALL SHARP EDGES. ALL MACHINED SURFACES TO HAVE A 125 RMS FINISH UNLESS NOTED OTHERWISE. THIRD ANGLE PROJECTION	DRAWN BY:	BG
	CHECKED BY:	WRB
	PROTOTYPE BY:	BG
	PROTOTYPE DATE:	9/6/2011
	APPROVED FOR PRODUCTION BY:	WRB
	PRODUCTION DATE:	10/18/2012

SALCO PRODUCTS, INC.
Hazarsolve® Division

PART NAME: **FLANGED HOSE BARB 6" 150 LB**

MATERIAL: **SEE BOM**

PROJECT #: **110906** SHEET #: **1 OF 1** SCALE: **1:1**

DRAWING #: **D31496** PART #: **HS6FTBSS**