

NO.	PART NAME	PART#	REQ'D	MATERIAL
1	ROUND BAR 4"	RNDBAR4UHDB	.63 FT	SALCO PE

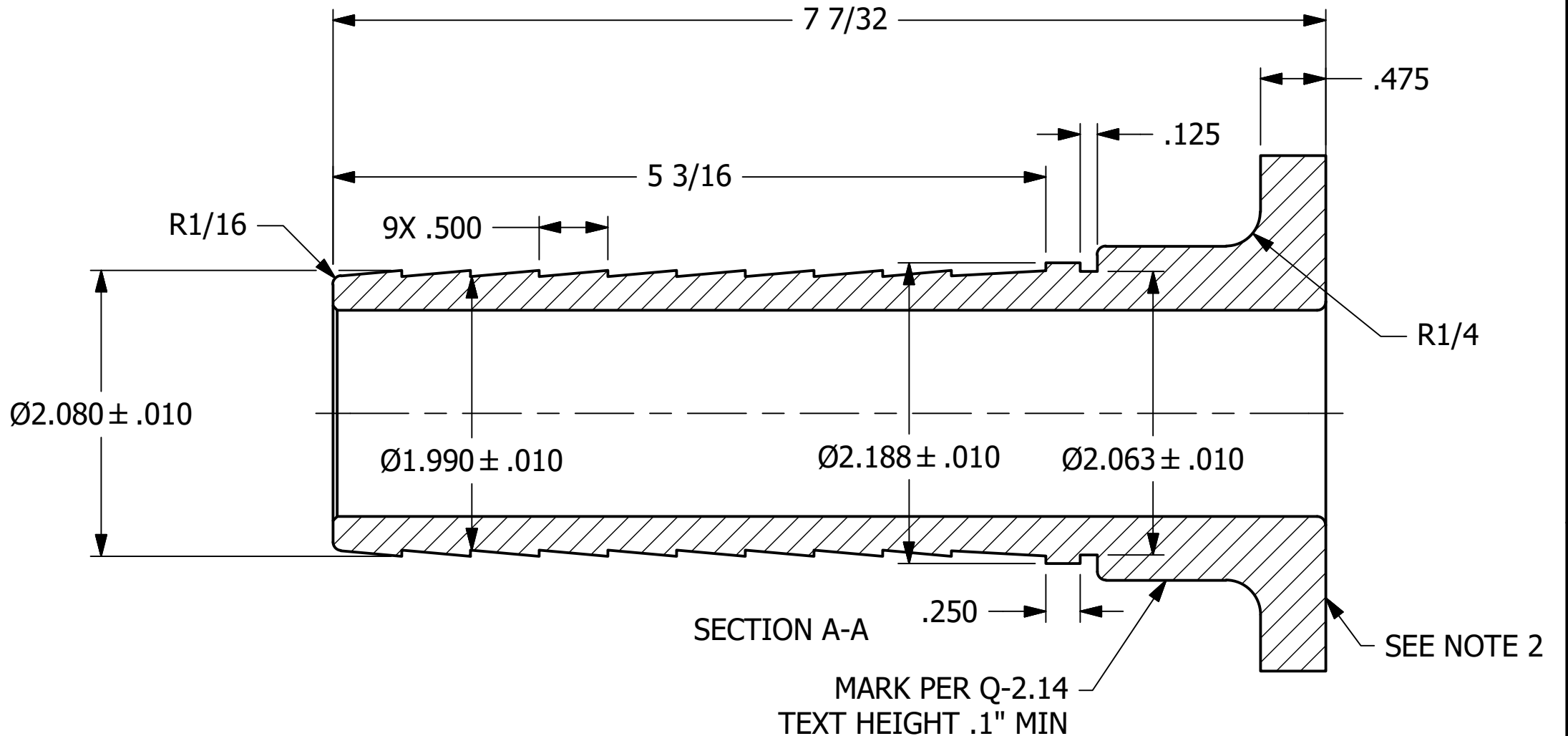
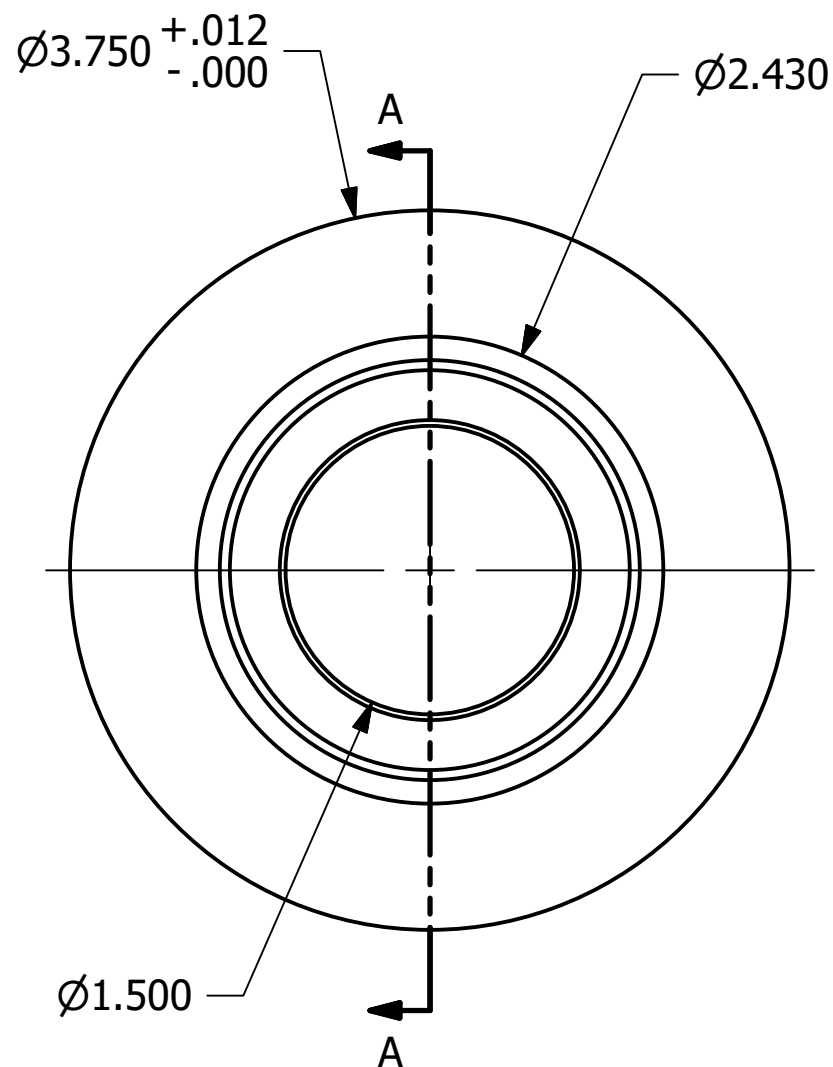

NOTES:

1. SEE DOCUMENT DSS 1 FOR MATERIAL SPECIFICATIONS.
2. SEE DOCUMENT DSS 5 FOR SERRATED GASKET SURFACE SPECIFICATIONS.
3. SEE DOCUMENT Q-2.14 FOR MARKING PROCEDURE.
4. ALL RADII TO BE 1/16" UNLESS NOTED OTHERWISE.

REV	BY	DATE	DESCRIPTION
D	TAK	12/13/19	Q-2.14 WAS QAP5A-1
C	WEB	1/3/18	UPDATED TO CURRENT STANDARDS, ADDED NOTES 3&4
B	VD	8/31/10	ADDED GROOVE, BOM. REV. NOTE.
A	ACC	12/17/03	ADDED PART INTO SYSTEM

UNLESS OTHERWISE SPECIFIED DIMENSIONAL TOLERANCES		DRAWN BY:	ACC
FRACTIONAL:	±1/16	CHECKED BY:	VD
X.XX:	±.03	PROTOTYPE DATE:	11/24/2003
X.XXX:	±.015	APPROVED FOR PRODUCTION BY:	ACC
ANGULAR:	±1°	PRODUCTION DATE:	12/16/2003
DEBURR ALL SHARP EDGES. ALL MACHINED SURFACES TO HAVE A 125 RMS FINISH UNLESS NOTED OTHERWISE.		SIZE:	B
THIRD ANGLE PROJECTION		DRAWING #:	18569

SALCO PRODUCTS, INC.

PART NAME: **HOSE BARB 2"**

MATERIAL: **SEE BOM/NOTE**

PROJECT #: **030708** SHEET #: **1 OF 1** SCALE: **1:1**

PART #: **HS2HBP**