

SALES DRAWING SALES DRAWING SALES DRAWING

SALES DRAWING

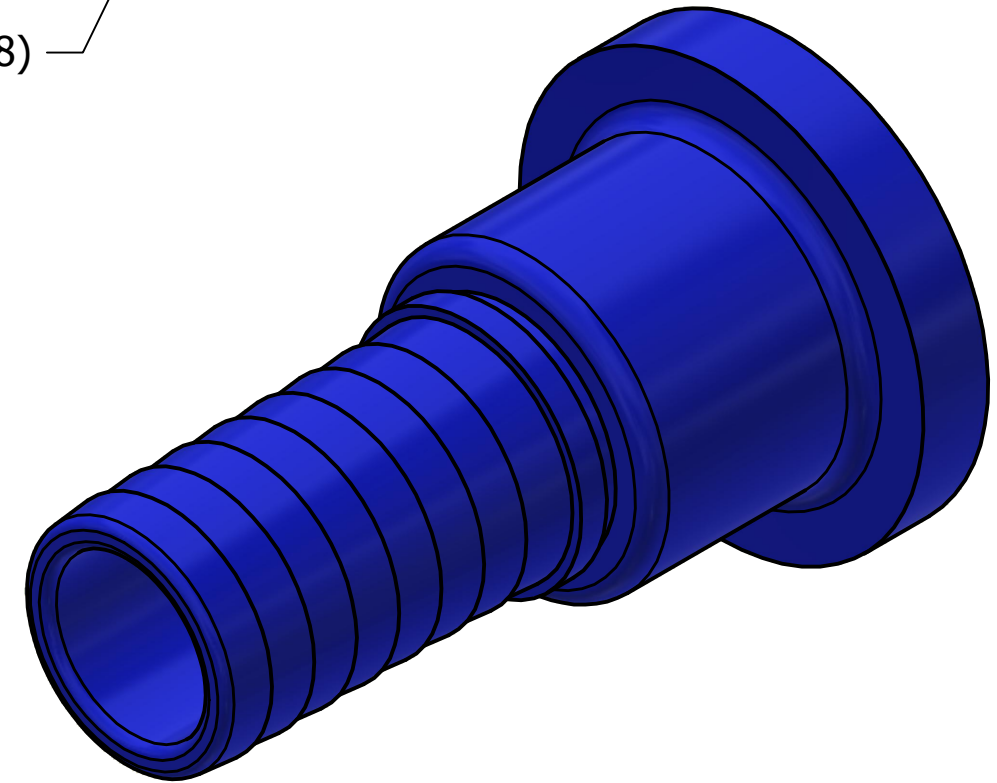
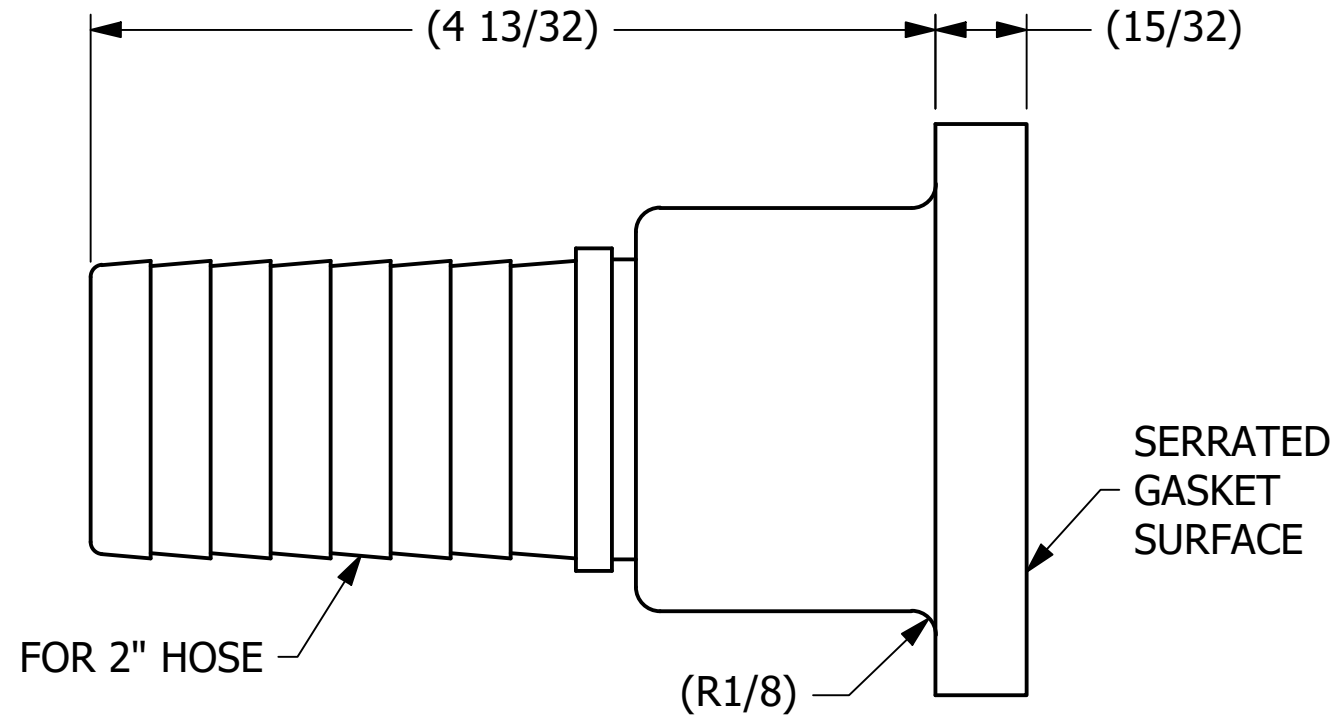
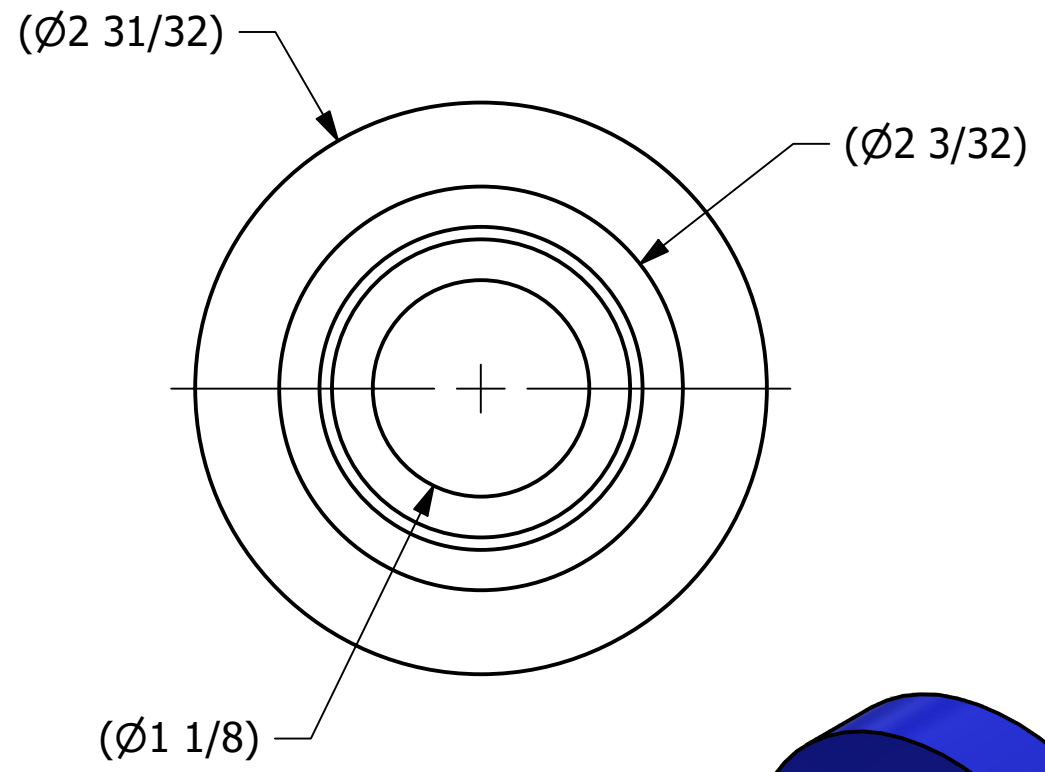

ISOMETRIC VIEW

C	WEB	12/6/12	202404051055	CHL
REV	BY	DATE	REF #	PUB
<b>SALCO PRODUCTS, INC.</b>				
PART NAME: HOSE BARB 1 1/2"				
MATERIAL: SALCO PE				
PROJECT #: 071105		SHEET #: 1 OF 1		SCALE: 1:1
PART #: HS15HBP				

<small>UNLESS OTHERWISE SPECIFIED DIMENSIONAL TOLERANCES</small> FRACTIONAL: ±1/16 X.XX: ±.03 X.XXX: ±.015 ANGULAR: ±1° <small>DEBURR ALL SHARP EDGES. ALL MACHINED SURFACES TO HAVE A 125 RMS FINISH UNLESS NOTED OTHERWISE.</small>	DRAWN BY:	CHL
	CHECKED BY:	PJG
	PROTOTYPE DATE:	9/21/2007
	APPROVED FOR PRODUCTION BY:	PJG
	PRODUCTION DATE:	4/2/2009
	SIZE:	B
THIRD ANGLE PROJECTION	DRAWING #:	24158